

Dissertation

**Effect of Eplerenone on Parathyroid Hormone Levels in
Primary Hyperparathyroidism**

submitted by

Dr.med.univ. Nicolas VERHEYEN

for the Academic Degree of

Doctor of Medical Science

(Dr. scient. med.)

at the

Medical University of Graz

Department of Internal Medicine

Division of Cardiology

under the Supervision of

Prim. Priv.Doiz. Dr.med.univ. Andreas Tomaschitz

Assoz.-Prof. Priv.Doiz. Dr.med.univ. Stefan Pilz, PhD

Prof. Dr.med. Burkert Pieske

Univ.-Ass. Dr.med.univ. Astrid Fahrleitner-Pammer

2018

1. Statutory Declaration

I hereby declare that this thesis is my own original work and that I have fully acknowledged by the name all individuals and organisations that have contributed to the research for this thesis. Due acknowledgement has been made in the text to all other material used. Throughout this thesis and in all related publications I followed the “Standards of Good Scientific Practice and Ombuds Committee at the Medical University of Graz”.

24th October 2018

2. Disclosures

All results of this thesis have been published in

- Tomaschitz A¹, Verheyen N^{2*}, Meinitzer A³, Pieske B^{2,4}, Belyavskiy E⁴, Brussee H², Haas J⁵, März W^{3,6,7}, Pieske-Kraigher E⁴, Verheyen S⁸, Ofner-Ziegenfuss L⁸, Hartaigh BÓ⁹, Schwetz V¹⁰, Aberer F¹⁰, Grübler M¹¹, Lang F¹², Alesutan I⁴, Voelkl J⁴, Gaksch M¹³, Horina JH¹⁴, Dimai HP¹⁰, Rus-Machan J¹⁵, Stiegler C¹⁰, Ritz E¹⁶, Fahrleitner-Pammer A¹⁰, Pilz S^{10*}. Effect of eplerenone on parathyroid hormone levels in patients with primary hyperparathyroidism: results from the EPATH randomized, placebo-controlled trial. *J Hypertens* 2016; 34(7):1347–56.

*contributed equally as first authors

- Verheyen N, Grübler MR, Meinitzer A, Trummer C, Schwetz V, Amrein K et al. Effect of eplerenone on markers of bone turnover in patients with primary hyperparathyroidism - The randomized, placebo-controlled EPATH trial. *Bone* 2017; 105:212–7.

Author information:

- ¹ Klinikum Bad Gleichenberg, Bad Gleichenberg, Austria
- ² Department of Cardiology, Medical University of Graz, Graz, Austria
- ³ Clinical Institute of Medical and Chemical Laboratory Diagnostics, Medical University of Graz, Graz, Austria
- ⁴ Medizinische Klinik mit Schwerpunkt Kardiologie, Campus Virchow-Klinikum, Charité -Universitätsmedizin Berlin, Berlin, Germany
- ⁵ Medical University of Graz, Department of Gynecology and Obstetrics, Austria
- ⁶ Synlab Academy, Synlab Services LLC, Germany
- ⁷ Medical Clinic V (Nephrology, Hypertensiology, Endocrinology), Medical Faculty Mannheim, Ruperto Carola University Heidelberg, Mannheim, Germany
- ⁸ Institute of Human Genetics, Medical University of Graz, Graz, Austria

- ⁹ Department of Radiology, Dalio Institute of Cardiovascular Imaging, New York-Presbyterian Hospital and the Weill Cornell Medical College, New York, New York
- ¹⁰ Department of Internal Medicine, Division of Endocrinology and Diabetology, Medical University of Graz, Graz, Austria
- ¹¹ Swiss Cardiovascular Center Bern, Department of Cardiology, Bern University Hospital, Bern, Switzerland
- ¹² Department of Physiology, University of Tübingen, Tübingen, Germany
- ¹³ University Institute for Medical and Chemical Laboratory Diagnostics, Paracelsus Medical University, Salzburg, Austria
- ¹⁴ Department of Internal Medicine, Division of Nephrology, Medical University of Graz, Graz, Austria
- ¹⁵ Specialist Clinic for Rehabilitation Bad Aussee, Bad Aussee, Austria
- ¹⁶ Department of Medicine, Division of Nephrology, University Hospital Heidelberg, Heidelberg, Germany

Further published analyses from this thesis project include (ordered by date):

- Pilz S, Trummer C, Verheyen N, Schwetz V, Pandis M, Aberer F, et al. Mineralocorticoid Receptor Blockers and Aldosterone to Renin Ratio: A Randomized Controlled Trial and Observational Data. *Horm Metab Res.* 2018 May;50(5):375-382.
- Wetzel J, Pilz S, Grübler MR, Fahrleitner-Pammer A, Dimai HP, von Lewinski D, et al. Plasma parathyroid hormone and cardiovascular disease in treatment-naive patients with primary hyperparathyroidism: The EPATH trial. *J Clin Hypertens (Greenwich).* 2017 Nov;19(11):1173-1180.
- Verheyen N, Meinitzer A, Grübler MR, Ablasser K, Kolesnik E, Fahrleitner-Pammer A, et al. Low-grade inflammation and tryptophan-kynurenine pathway activation are associated with adverse cardiac remodeling in primary hyperparathyroidism: the EPATH trial. *Clin Chem Lab Med.* 2017 Jun 27;55(7):1034-1042.
- Verheyen N, Fahrleitner-Pammer A, Belyavskiy E, Gruebler MR, Dimai HP, Amrein K, et al. Relationship between bone turnover and LV function in

primary hyperparathyroidism: The EPATH trial. PLoS One. 2017 Apr 13;12(4):e0173799.

- Verheyen N, Fahrleitner-Pammer A, Pieske B, Meinitzer A, Belyavskiy E, Wetzel J, Gaksch M, et al. Parathyroid hormone, aldosterone-to-renin ratio and fibroblast growth factor-23 as determinants of nocturnal blood pressure in primary hyperparathyroidism: the eplerenone in primary hyperparathyroidism trial. J Hypertens. 2016 Sep;34(9):1778-86
- Tomaschitz A, Verheyen N, Gaksch M, Meinitzer A, Pieske B, Kraigher-Krainer E, et al. Homoarginine in patients with primary hyperparathyroidism. Am J Med Sci. 2015 Apr;349(4):306-11
- Tomaschitz A, Fahrleitner-Pammer A, Pieske B, Verheyen N, Amrein K, Ritz E et al. Effect of eplerenone on parathyroid hormone levels in patients with primary hyperparathyroidism: a randomized, double-blind, placebo-controlled trial. BMC Endocr Disord 2012; 12:19.

I confirm that all co-authors have explicitly agreed to the use of their data in the thesis and that I have obtained permission to reproduce all figures cited in this thesis, as described in detail in the respective figure captions.

3. Acknowledgements

As a doctoral student I received funding from the Austrian Society of Bone and Mineral Research (OEGKM, Felix-Bronner Grant 2014 and Project Prize 2014) and from the Medical University of Graz through the Doctoral School “Molecular Medicine and Inflammation” (MOLMED). The underlying project of this dissertation was supported by funding from the Austrian National Bank (Jubilaeumsfond: project number 14621; recipient: Andreas Tomaschitz).

My personal thanks go to my supervisors and mentors Andreas Tomaschitz and Stefan Pilz. It was their continuous motivation, leadership and their high standard who motivated me to work at my limit. Even so, the conduct of the EPATH study would not have been possible without the support of Burkert Pieske and Astrid Fahrleitner-Pammer who were always there when help was needed, nor without Evgeny Belyavskiy. I thank all my colleagues from the Department of Cardiology who see clinical research as an integral part of university medicine.

My thanks go to my parents, and also to my parents-in-law, for their never-ending support. Above all, I thank my wife Sarah and my children Jonathan and Mira who accompanied me and gave me the strength to bring this study to an end.

4. Table of Contents

1. Statutory Declaration.....	2
2. Disclosures.....	3
3. Acknowledgements.....	6
4. Table of Contents.....	7
5. Abbreviations and Definitions.....	10
6. List of Figures.....	11
7. List of Tables.....	12
8. Abstract in German.....	13
9. Abstract in English.....	15
10. Introduction.....	17
10.1. Physiology of parathyroid hormone.....	17
10.1.1. Secretion and degradation.....	17
10.1.2. Regulation of calcium homeostasis.....	19
10.1.3. Regulation of bone metabolism.....	20
10.2. Interaction between aldosterone and parathyroid hormone.....	21
10.3. Primary hyperparathyroidism.....	23
10.3.1. Risk factors.....	23
10.3.2. Epidemiology.....	27
10.3.3. Clinical presentation.....	29
Signs.....	29
Symptoms.....	31
10.3.4. Treatment of primary hyperparathyroidism.....	32
10.3.5. Bone disease in primary hyperparathyroidism.....	33
10.3.6. Cardiovascular disease in primary hyperparathyroidism.....	35

Mechanisms.....	35
Cardiovascular outcomes.....	38
Cardiac structure and function and arterial hypertension.....	39
10.3.7. Interaction between parathyroid hormone and aldosterone in primary hyperparathyroidism.....	42
11. Research question.....	44
12. Material and Methods.....	45
12.1. Study design (138, 139).....	45
12.2. Study funding (138, 139).....	47
12.3. Participants (138, 139).....	47
12.4. Intervention (138, 139, 143).....	49
12.4.1. Primary outcome measure.....	49
12.4.2. Secondary outcome measures.....	49
12.5. Measurements (138, 139, 143).....	49
12.6. Sample size considerations (138, 139, 143).....	52
12.7. Statistical methods (138, 139, 143).....	52
12.8. Cross-sectional analyses (143).....	53
13. Results – Findings (139, 143).....	54
13.1. General (139).....	54
13.2. Baseline characteristics (139).....	56
13.3. Primary endpoint (139).....	58
13.4. Secondary endpoints (139, 143).....	59
13.6. Cross-sectional analyses (143).....	62
14. Discussion.....	64
Aspects of study design.....	64
Urinary calcium excretion.....	67
Arterial hypertension.....	67

Cardiac structure and function parameters.....	70
Gender disparity.....	71
Normocalcemic primary hyperparathyroidism.....	71
Limitations and strengths.....	75
Conclusion.....	75
15. Bibliography.....	76

5. Abbreviations and Definitions

BALP, bone-specific alkaline phosphatase

BMD, bone mineral density

BP, blood pressure

CTX, carboxy-terminal collagen crosslinks

DBP, diastolic blood pressure

DXA, dual-energy X-ray absorptiometry

EPATH study, Eplerenone in primary HyperPARaTHyroidism study

FHH, familial hypocalciuric hypercalcemia

iPTH, intact parathyroid hormone

LV, left ventricular

MEN, multiple endocrine neoplasia

MR, mineralocorticoid receptor

MRA, mineralocorticoid receptor antagonist

NT-proBNP, N-terminal pro-brain B-type natriuretic peptide

OC, osteocalcin

P1NP, procollagen type I N propeptide

PTH, parathyroid hormone

RAAS, renin-angiotensin-aldosterone-system

RANK, receptor activator of nuclear factor kappa-B

RANKL, receptor activator of nuclear factor kappa-B ligand

RCT, randomized controlled trial

RR, relative risk

SBP, systolic blood pressure

VDR, vitamin D receptor

ZG, zona glomerulosa

6. List of Figures

Figure 1: Structure of human parathyroid hormone fragment 1-34. (3)

Figure 2: Parathyroid hormone response to decreased ionised calcium (7) .

Figure 3: Age-related gender distribution of patients undergoing parathyroidectomy in the Nationwide Inpatient Sample (NIS) database for the years 2000–2004 by 5-year intervals.

Figure 4: Suggested pathways of the interplay between PTH and the renin–angiotensin–aldosterone system in the setting of PTH excess. (89)

Figure 5: Relationship between plasma parathyroid hormone and mean nocturnal systolic blood pressure in a multivariate model (A). Relationship between plasma parathyroid hormone and mean nocturnal diastolic blood pressure in a multivariate model (B). (118)

Figure 6: Flowchart of the EPATH trial. (138)

Figure 7: Flowchart showing the number of participants screened, excluded, randomized and analyzed for primary outcome. (139)

Figure 8: Scatter plots depicting bivariate correlations between plasma parathyroid hormone and mean 24-hour pulse wave velocity (A), mean left ventricular mass index (B), and mean nocturnal systolic blood pressure (C).

Figure 9: Effect of blood pH on parathyroid hormone in dogs with metabolic acidosis (closed circles) and with respiratory acidosis (open square).

7. List of Tables

Table 1: Changing clinical presentation of primary hyperparathyroidism

Table 2: Indications for surgery for the treatment of asymptomatic primary hyperparathyroidism according to Canadian and International recommendations

Table 3: Demographic and Clinical Baseline Characteristics

Table 4: Primary outcome variables at baseline and follow-up, and changes from baseline in study participants with available values at both study visits

Table 5: Secondary outcome variables at baseline and follow-up, and changes from baseline in study participants with available values at both study visits

Table 6: Outcome variables at baseline and follow-up, and changes from baseline in study participants with available values at both study visits

Table 7: Cross-sectional bi-variate correlations between bone turnover markers and parameters of the renin-angiotensin-aldosterone system.

8. Abstract in German

Hintergrund

Zunehmende Evidenz deutet auf ein gegenseitiges Wechselspiel zwischen Parathormon (PTH) und Aldosteron. Beim primären Hyperparathyreoidismus (pHPT) wird dies immer mehr als potentieller Mechanismus hinter dem erhöhten Risiko für kardiovaskuläre und Knochen-Erkrankungen vermutet.

Methoden

Die randomisierte, doppelblinde, Plazebo-kontrollierte Effekt von Eplerenon auf PArATHormon Spiegel bei PatientInnen mit primärem Hyperparathyreoidismus (EPATH) Studie hatte als Hauptziel das Testen der Hypothese, dass der Mineralokortikoid Rezeptor Antagonist Eplerenon Plasma Konzentrationen von intaktem PTH (iPTH) bei PatientInnen mit pHPT verändert. Surrogat-Parameter der kardiovaskulären und Knochen-Gesundheit wurden als sekundäre Entpunkte ausgewertet.

Ergebnisse

Unter Berücksichtigung von Individuen mit einer biochemischen Diagnose eines pHPT, 25-Hydroxyvitamin D ≥ 20 ng/ml und geschätzter glomerulärer Filtrationsrate > 50 ml/min/1.73m² wurden 110 PatientInnen eingeschlossen. Sie wurden 1:1-randomisiert einer Behandlung mit 25mg Eplerenon einmal täglich (Auftitrieren nach 4 Wochen zu 50 mg/Tag) oder passendem Placebo für eine Behandlungsdauer von 8 Wochen zugewiesen. Das mittlere Alter lag bei $67,5 \pm 9,5$ Jahren, 78,4% waren Frauen. Von allen TeilnehmerInnen beendeten 97 erfolgreich die Studie und waren für die Analyse des primären Endpunkts verfügbar. Der mittlere Behandlungseffekt (95% Konfidenz Intervall) auf iPTH lag bei 1,0 (0,9 bis 1,1; P=0.777) pg/ml. Der mittlere 24-Stunden Blutdruck sank signifikant um -6,3 (-9,4 bis -3,3)/-3,7 (-5,7 bis -1,7) mmHg. In keinem weiteren, sekundären Endpunkt wurden signifikante Unterschiede beobachtet. Die Rate an unerwünschten Ereignissen war in beiden Gruppen gleich.

Schlussfolgerung

Behandlung mit Eplerenon hatte im Vergleich mit Placebo neutrale Effekte auf zirkulierende Plasma Spiegel von PTH. Eplerenon senkte signifikant den Blutdruck, wurde gut vertragen und erwies sich als sicher.

9. Abstract in English

Background

Mounting evidence supports the concept of a reciprocal interaction between parathyroid hormone (PTH) and aldosterone. This interweavement is increasingly seen as a potential mechanistic background for increased risk of cardiovascular disease and osteoporosis in primary hyperparathyroidism (pHPT).

Methods

The single-center, randomized, double-blind, parallel-group, placebo-controlled Effect of Eplerenone on PArATHyroid hormone levels in patients with primary hyperparathyroidism (EPATH) trial had the primary aim to test the hypothesis that the mineralocorticoid receptor antagonist eplerenone alters plasma concentrations of intact PTH (iPTH) in patients with pHPT. Surrogate parameters of cardiovascular health and bone turnover markers were evaluated as secondary endpoints.

Results

Including subjects with a biochemical diagnosis of pHPT, 25-hydroxyvitamin D \geq 20 ng/ml and estimated glomerular filtration rate > 50 ml/min/1.73m², we enrolled 110 individuals. Subjects were 1:1 randomly assigned to receive either 25mg eplerenone once daily (up-titration after 4 weeks to 50 mg/day) or matching placebo for a treatment period of 8 weeks. Mean age \pm SD was 67.5 \pm 9.5 years and 78.4% were female. Study participation was successfully finalized in 97 subjects who were eligible for the primary endpoint analysis. The mean treatment effect (95% confidence interval) on iPTH was 1.0 (0.9–1.1; P=0.777) pg/ml. Mean 24-h ambulatory blood pressure decreased significantly by -6.3 (-9.4 to -3.3)/-3.7 (-5.7 to -1.7) mmHg. No differences were seen in any further secondary endpoints. The rate of adverse events was similar between groups.

Conclusion

Treatment with eplerenone had neutral effects on circulating plasma levels of iPTH when compared to placebo. Eplerenone significantly lowered blood pressure and was well tolerated and safe.

10. Introduction

10.1. Physiology of parathyroid hormone

10.1.1. Secretion and degradation

Parathyroid hormone (PTH, PTH 1-84, intact PTH) consists of 84 amino acids and has a molecular mass of 9400 Dalton. Its precursor protein pre-pro PTH is a 115-amino acid polypeptide being synthesized in chief cells of the parathyroid glands. Pre-pro PTH is cleaved within chief cells at the N-terminal end to pro-PTH (90 amino acids) and further to PTH.(2) PTH 1-84 has a plasma half-life between two and four minutes. In contrast to this, the C-terminal fragments, which are cleared by the kidney, have half-lives that are five to ten times greater (see **Figure 1**). PTH 1-84 accounts for approximately 20 percent of the total circulating PTH proteins, under physiological conditions. Under hypocalcemic conditions the proportion of PTH 1-84 may increase up to 33%, while it may decrease to 4% in the setting of hypercalcemia. PTH is rapidly cleared from plasma through uptake by the liver and kidney, where PTH 1-84 is cleaved into amino- and carboxyl-terminal fragments that are then eliminated by the kidney. As a result, circulating immunoreactive PTH in healthy adults comprises:

Intact PTH - 5 to 30 percent

C-terminal fragments - 70 to 95 percent

N-terminal fragments - < 5 percent

It appears that the N-terminal fragment 1-34 (PTH 1-34) is sufficient for interaction between the hormone and its ubiquitously expressed receptor, the PTH-1 receptor (PTH1R).

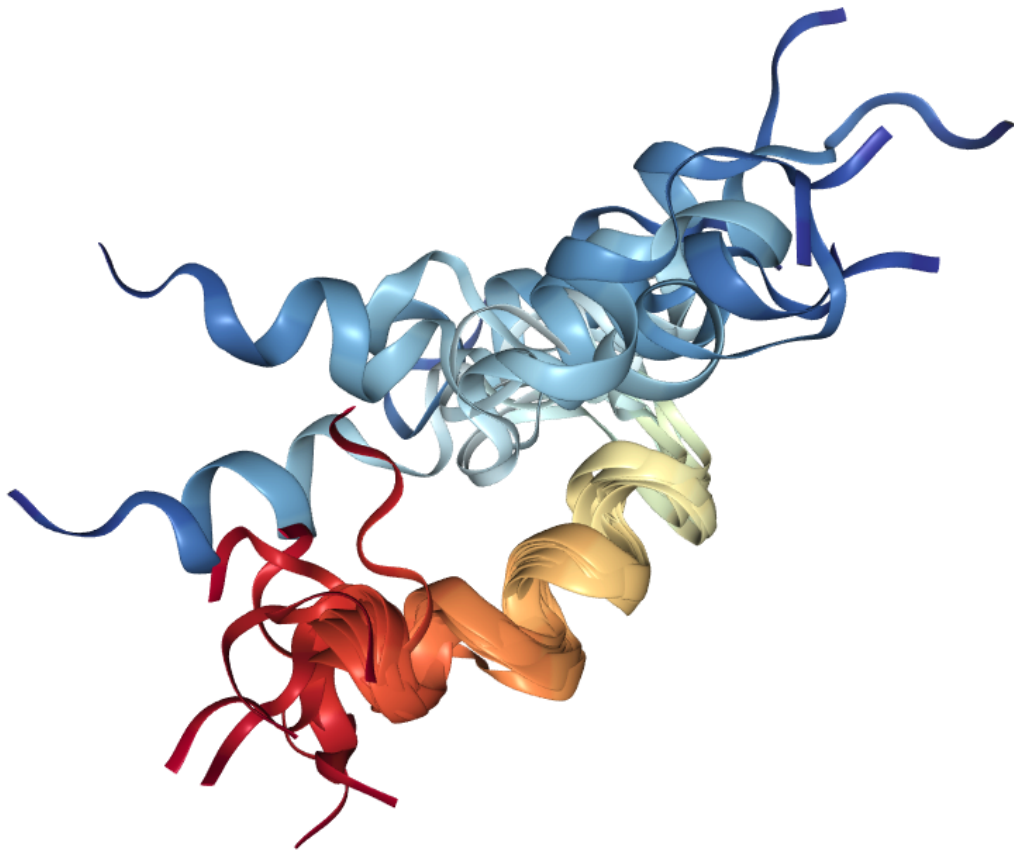

Figure 1: Structure of human parathyroid hormone fragment 1-34.(3)

Cited from Marx UC, Adermann K, Bayer P, Forssmann WG, Rösch P. Solution structures of human parathyroid hormone fragments hPTH(1-34) and hPTH(1-39) and bovine parathyroid hormone fragment bPTH (amino acids 1-37). *Biochem Biophys Res Commun.* 2000 Jan 7;267(1):213-20.

<https://www.sciencedirect.com/science/article/pii/S0006291X99919587?via%3Dihub>. Permission for reuse in a thesis obtained from Elsevier.

PTH secretion from chief cells in response to circulating calcium concentrations is mainly regulated via the calcium-sensing receptor (CaSR). The CaSR is a G-protein coupled receptor with its gene being located on chromosome 3 in humans. (4) As a transmembraneous receptor the CaSR is activated by ionized calcium and induces suppression of secretion of PTH 1-84 into the circulation.(5)

Active vitamin D (1,25-dihydroxyvitamin D, calcitriol) contributes to PTH secretion by binding to and activating the vitamin D receptor (VDR) that is expressed on the

surface of parathyroid chief cells. VDR activation leads to suppression of pre-pro PTH synthesis.(6)

10.1.2. Regulation of calcium homeostasis

PTH crucially regulates calcium and phosphate homeostasis via the kidneys, bone, and indirectly via the intestine with the aim to maintain calcium and phosphate concentrations within their normal ranges. These are 1.15 to 1.35 mmol/L for ionized calcium and 2.15 to 2.55 mmol/L for albumin-adjusted calcium.

PTH increases plasma Ca^{2+} concentration in three different ways: (1) in the presence of permissive amounts of vitamin D it stimulates bone turnover by activating osteoclasts and osteoblasts; (2) it increases intestinal Ca^{2+} and phosphate absorption by activating the 1α -hydroxylase thereby triggering the synthesis of active vitamin D in the kidney, and (3) it enhances active renal Ca^{2+} reabsorption. These PTH-mediated calcium elevations in turn lower PTH secretion as part of an autoregulatory loop. PTH and calcium regulatory feedback loops are illustrated in **Figure 2**.

In healthy individuals, a reduction in serum ionized calcium of 0.1 mg/dL (0.025 mmol/L) leads to an increase in PTH concentrations within minutes; vice versa, an increase in serum ionized calcium instantaneously reduces circulating PTH concentrations

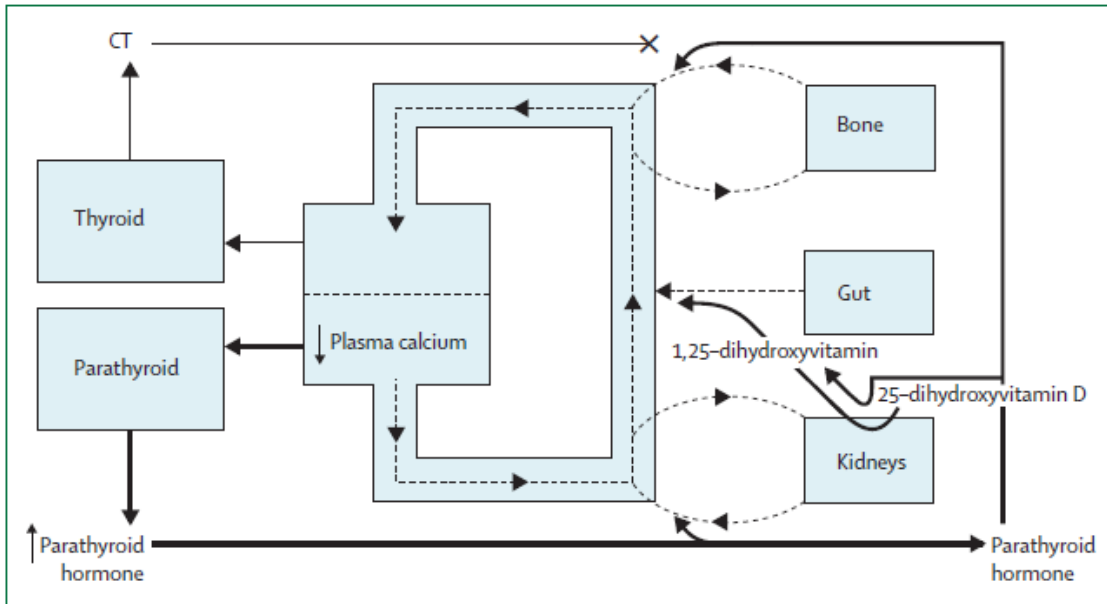

Figure 2: Parathyroid hormone response to decreased ionised calcium (7)

Cited from Fraser WD. Hyperparathyroidism. *Lancet*. 2009 Jul 11;374(9684):145-58. doi: 10.1016/S0140-6736(09)60507-9

[https://www.thelancet.com/journals/lancet/article/PIIS0140-6736\(09\)60507-9/fulltext](https://www.thelancet.com/journals/lancet/article/PIIS0140-6736(09)60507-9/fulltext) Permission for reuse in a thesis obtained from Elsevier.

10.1.3. Regulation of bone metabolism

Bone remodeling is a continuous dynamic process serving to maintain 1) bone turnover in a physiological balance between bone formation and bone resorption; 2) circulating levels of calcium and phosphate within physiological ranges. Imbalance of bone remodeling can lead to inappropriate bone resorption and finally to osteoporosis, or to inappropriate ossification and ectopic calcification. Apposition and resorption are closely coupled processes taking place in the bone micro-environment.

Bone formation is mainly orchestrated by cells of osteoblastic lineage, most importantly by osteoblasts which 1) produce osteoid (ie. bone collagen); 2)

synthesize bone-resorption regulating proteins such as receptor activator of nuclear factor kappa-B ligand (RANKL); and 3) differentiate into osteocytes to form mature bone tissue. Osteoblasts and osteocytes also secrete hormones such as osteocalcin (OC) or fibroblast-growth-factor 23 and exert thereby systemic pleiotropic immunoregulatory, cardio-regulatory and metabolic effects.(8) Upon activation and during the bone formation process, collagen byproducts such as procollagen type I N propeptide (P1NP), and enzymes such as bone-specific alkaline phosphatas (BALP), accumulate in the bone microenvironment and their systemic concentration reflects the amount of bone formation.(9)

Bone resorption on the other hand is mainly regulated by osteoclasts which initiate enzymatic bone deconstruction. Osteoclastogenesis and activation of osteoclasts by binding of RANKL to receptor activator of nuclear factor kappa-B expressed on osteoclasts complement osteoblastic bone formation and are closely coupled with osteoblast activity. Carboxy-terminal collagen crosslinks (CTX) is a major component of the bone matrix and, upon bone resorption by osteoclasts, is secreted into the circulation and can be measured as a surrogate of bone resorption.

By binding to the PTH1R which is expressed on osteoblasts and osteocytes, PTH crucially regulates differentiation, proliferation and activation of osteoblastic cells and thereby indirectly stimulates osteoclastogenesis and osteoclast activation.(10–12)

10.2. Interaction between aldosterone and parathyroid hormone

The mineralocorticoid receptor (MR) is expressed in normal parathyroid cells and nuclei of parathyroid adenomata and the PTH receptor is expressed in both aldosterone producing adrenal adenoma cells and hyperplasia cells which points towards a mutual interrelation between aldosterone and PTH.(13–15)

Olgaard et al. investigated the effect of PTH on the calcium-mediated aldosterone secretion from isolated, purified zona glomerulosa (ZG) cells obtained from the rat. Cells were pre-incubated with calcium and PTH (1-84) or PTH (1-34) were added. In all cell preparations with PTH (1-84) as well as PTH (1-34) the aldosterone responses to a certain Ca^{2+} concentration increased significantly by up to 200% (p

< 0.001) above baseline values. The authors suggested that PTH may have a Ca^{2+} ionophore-like effect on endocrine glands, which are not normally related to PTH and thus enhance the calcium-stimulated hormone secretion.(16) One mechanistic study documented increased intracellular calcium levels in ZG cells resulting in pronounced aldosterone synthesis in the setting of PHPT.(17)

One study assessed the effects of chronic (12 days) continuous intravenous b-(1-34) PTH infusion in normal human subjects and found significant increases in urinary tetrahydroaldosterone excretion in parallel to the development of hypercalcemia and hypertension. No changes of serum potassium and plasma renin activity have been seen. The authors concluded that the elevation of aldosterone and development of hypertension associated with clinical pHPT results from either direct or indirect effects of PTH excess, per se, and requires neither the long-term consequences/complications of the clinical disorder (e.g., severe nephrocalcinosis, renal insufficiency) nor primary hypersecretion of additional hormones.(18)

Isales et al examined the effect of PTH on aldosterone secretion from isolated bovine adrenal glomerulosa cells. Again, PTH was shown to stimulate aldosterone secretion in a dose-dependent manner and to potentiate aldosterone secretion in response to angiotensin II. PTH elicited a small increase in the intracellular Ca^{2+} concentration and cAMP content in glomerulosa cells. In cells pre-treated with angiotensin II or potassium, the intracellular calcium response to PTH was markedly potentiated. Thus, PTH might stimulate aldosterone secretion from adrenal glomerulosa cells, both alone and in combination with angiotensin II.(19)

In a case series on 10 subjects with primary aldosteronism published five years later, the majority had elevations of PTH concentrations (mean, 645 +/- 109 pgeq/liter; normal, less than 150 to 375 pgeq/liter). The authors concluded that parathyroid hypersecretion is a common feature of primary aldosteronism and also hypothesized a physiologic relationship between the activity of the renin-aldosterone system and parathyroid physiology.(20)

Further studies suggested a mechanistically relevant association between PTH and renin, indicating indirect PTH mediated stimulation of aldosterone synthesis via increased renal renin release.(21–23)

10.3. Primary hyperparathyroidism

Primary hyperparathyroidism (pHPT) is characterized by inappropriately high PTH concentrations in relation to the circulating calcium concentrations. PHPT is a primary disorder of one or more of the parathyroid glands either due to parathyroid gland hyperplasia or PTH secreting isolated or multiple adenomata leading to autonomous oversecretion of PTH. The most common cause is a single-PTH producing adenoma (~ 80%), while multigland adenoma/parathyroid gland hyperplasia are less often causes of PTH excess (~ 1 to 15%). Parathyroid carcinoma or ectopic glands i.e. within the mediastinum or around the thyroid gland have been reported as rare causes.(2)

10.3.1. Risk factors

Although the precise cause of pHPT is unknown, several risk factors have been identified that set individuals at higher risk to develop pHPT. These include female sex, exposure to radiation and sedentary lifestyle, as summarized in more detail in the following paragraphs.

Exposure to radiation particularly in the neck or head regions has been identified as a risk factor of pHPT. In an North American case control study published in 1989, patients who had been operated for pHPT were compared to healthy age- and sex-matched controls with regard to their history of exposure to therapeutic radiation (a meanwhile historical treatment option for acne). They found that pHPT patients had more often had radiation exposure (OR 1.9 [95% CI, 0.9 - 4.4]). When including only patients with a history of head or neck radiation, the OR was as high as 2.3 (95% CI, 0.9 - 5.7). (24) Fujiwara and colleagues hypothesized that nuclear radiation may increase the risk of pHPT and studied a Japanese population of atomic bomb survivors (n=3.984) and controls. They found that atomic bomb survivors had a higher likelihood to develop pHPT (OR 4.1 at 1 Gy [95% CI, 1.7 –

14]).(25) Schneider et al investigated the risk of pHPT among subjects who had received external beam radiotherapy to the head and neck area between 1939 and 1962 and before their 16th birthday, for the treatment of benign conditions. After a mean follow-up of 36.6 years, 36 cases of pHPT were diagnosed and radiation dose was correlated with the occurrence of pHPT. The authors interpreted their results as evidence of a dose-dependent relationship between radiation exposure and pHPT and postulated pHPT screening in individuals irradiated during childhood.(26) By contrast, elderly patients with hyperthyroidism who underwent radioactive iodine therapy had a risk to develop pHPT that was similar to the general population, although it must be noted that this study had only a mean follow-up of 7,4 years. (27)

Females are approximately three times more often affected by pHPT than men so that female gender is considered a risk factor of pHPT. In a 20% random sample of all hospital stays in the United States between 2000 and 2004, 10.190 patients were operated for pHPT and 7.513 were females (73%). Interestingly, the onset of significant disparity between genders was evident from the age of 50, see **Figure 3**. The authors conclude that estrogen deficiency during postmenopause may therefore only partially explain the higher prevalence of pHPT in women, however their study design has not been designed to offer alternative explanations. They speculate that estrogen deficiency during pregnancy may also contribute to this phenomenon.(28) Another possible explanation for less pHPT diagnoses in men may result from the lack of metabolic screening programmes for men, while recommendations exist for postmenopausal women to undergo screening for osteoporosis which includes all parameters necessary to diagnose pHPT.

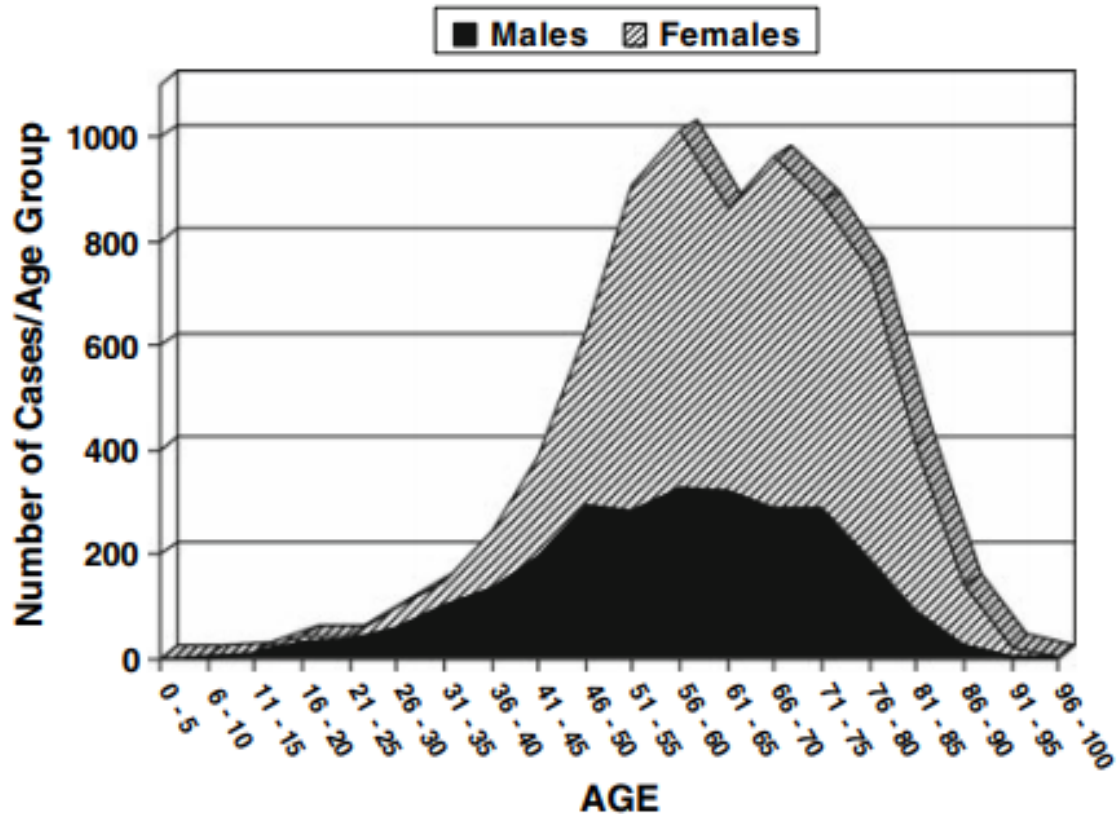

Figure 3: Age-related gender distribution of patients undergoing parathyroidectomy in the Nationwide Inpatient Sample (NIS) database for the years 2000–2004 by 5-year intervals. (28)

Cited from Miller BS, Dimick J, Wainess R, Burney RE. Age- and sex-related incidence of surgically treated primary hyperparathyroidism. *World J Surg.* 2008 May;32(5):795-9. doi: 10.1007/s00268-007-9427-2.

<https://link.springer.com/article/10.1007%2Fs00268-007-9427-2>. Permission for reuse in a thesis obtained from Springer.

In 5 – 10 % of cases, pHPT can be due to genetic causes such as multiple endocrine neoplasia type (MEN)-1, a rare autosomal dominant inherited condition caused by mutations in the MEN-1 gene.(29) MEN-1 should be suspected when pHPT occurs at an early age or if tumors of the pituitary gland or of pancreatic islets occur in concurrence. Even more rarely, pHPT can result from MEN-2A ((RET oncogene mutations), MEN-4 ((CDKN1B mutations) or hyperparathyroidism-jaw tumor. They are summarized in the present pHPT guidelines.(30)

In rare cases a constellation of hypercalcemia and hyperparathyroidism may be due to the genetic disorder familial hypocalciuric hypercalcemia (FHH) and not due to primary parathyroid disease. FHH is largely underdiagnosed due to expensive and laborious genetic testing procedures.(31) As a consequence, FHH patients are frequently diagnosed as pHPT and undergo potentially harmful parathyroidectomy. (32) Several approaches have therefore been undertaken to identify biomarkers that may help distinguishing FHH patients from pHPT patients. Assessment of the 24-hour urinary calcium clearance/creatinine clearance ratio (CCCR) is the most established parameter. However, up to 20% of pHPT patients show a CCCR below the proposed cut-off of 0.115. (32, 33) There are three types of FHH classified depending on the altered gene. FHH1 is caused by inactivating mutations in the CaSR gene and accounts for approximately 47 -56% of all FHH cases. To this point, up to 140 different CaSR mutations have been shown to cause FHH1. (34, 35) FHH2 is caused by a missense mutation or a deletion in GNA1.(36) FHH3 is considered to constitute approximately 20% of FHH cases and is caused by missense mutations in AP2S1.(37)

Vaidya and his group studied the role of life style diseases (arterial hypertension, body size, low calcium intake, low physical activity) as predictors of pHPT in a series of publications mainly including only females. They analysed the longitudinal prospective Nurses' Health Study I including 75.600 female nurses who did not have a diagnosis of pHPT at baseline. During follow-up, those 347 individuals who developed pHPT had a significantly higher rate of arterial hypertension in their baseline data assessment. In fact, the multivariate-adjusted relative risk (RR) for those with arterial hypertension to develop pHPT was 1.45 (95% CI, 1.10-1.91). Interestingly, loop diuretic treatment was an independent predictor of incident pHPT when compared to other antihypertensive drugs, with a multivariate-adjusted RR of 1.71 (95% CI, 1.08-2.71).(38) Using data from the same study they found that individuals with physical activity in the highest quintile had a 50% lower risk to develop pHPT than those with physical activity in the lowest quintile (age-adjusted RR 0.50 (95% CI, 0.35–0.73). There was a linear trend between physical activity at baseline and incident pHPT (P for trend < 0.001). Adding low calcium intake as an independent variable, those with high physical activity could be again subdivided in terms of risk for incident pHPT so

that those with high physical activity but low calcium intake again had a significantly higher risk to develop pHPT.(39) Using an even larger dataset from the Nurses' Health Study (n=85.013) they evaluated the predictive role of several indices of body size for incident pHPT. Nurses with weight circumference in the highest quartile when compared to those in the lowest quartile had a significantly higher risk to develop pHPT (multivariate-adjusted RR 2.27 [95% CI, 1.63, 3.18]; p for trend across quartiles < 0.001). Similarly, weight turned out as a significant predictor of incident pHPT (quartile 4 vs quartile 1: RR 1.65 [1.24, 2.19]; p for trend across quartiles < 0.001). Interestingly, the association between BMI and incident pHPT did not reach statistical significance (p for trend 0.07).(40)

10.3.2. Epidemiology

PHPT is the third most common endocrine disorder.(7) The incidence of pHPT appears to have changed around the 1970s due to improvements in diagnostics. Before PTH assays became widely available and plasma calcium measurement became part of routine biochemical investigations (~ 1970), patients with pHPT were in the majority diagnosed when they presented with clinical signs and symptoms. The classical symptom triad of advanced disease comprises urolithiasis, gastritis or gastric ulcer and osteoporosis with osteitis fibrosa cystica being the advanced form.

Since the 1970s, according to a systematic review by Fraser, prevalences have been described at 3 to 21 per 1000 in Scandinavian countries and 1 per 1000 in the USA.(41–43) In the US, two incidence peaks in the years 1974 and 1998 have been identified(44), and an overall decline of pHPT was observed. It was speculated that this is due to 1) the so-called “catch-up effect” of individuals who already had pHPT before the 1970s but had not been diagnosed; 2) the disappearance of irradiation as one common cause of pHPT.(45) As with many acquired diseases, the incidence of pHPT diagnosis is age-dependent. Women are approximately 2-fold affected compared to men. Most women are diagnosed in early post-menopause, often as incidental findings during osteoporosis screening.
(45)

Since the last two decades, the biochemical presentation at diagnosis appears to have been stable, at least in the South of Europe.(46) However, with the introduction of 2nd and 3rd generation of PTH assays, most of patients are diagnosed by incidentally detected hypercalcemia or during osteoporosis screenings (47) and are still asymptomatic at the time of presentation, see **Table 1**.

	1930-1970	1970-2000
Nephrolithiasis	51-57%	17-37%
Hypercalciuria	36%	40%
Overt skeletal disease	10-23%	1-4-14%
Asymptomatic	0-6-18%	22-80%

Table 1: Changing clinical presentation of primary hyperparathyroidism (7)

Cited from Fraser WD. Hyperparathyroidism. Lancet. 2009 Jul 11;374(9684):145-58. doi: 10.1016/S0140-6736(09)60507-9

[https://www.thelancet.com/journals/lancet/article/PIIS0140-6736\(09\)60507-9/fulltext](https://www.thelancet.com/journals/lancet/article/PIIS0140-6736(09)60507-9/fulltext). Permission for reuse in a thesis obtained from Elsevier.

Recent studies aiming to determine the prevalence of pHPT therefore focus on the diagnosis of forms that are considered to occur early in the disease course of pHPT. These include normocalcemic pHPT and asymptomatic hypercalcemic pHPT.

In the Osteoporotic Fractures in Men study, the incidence of normocalcemic pHPT among 2364 men was 0.4% (n=9), while it was 3.1% (n=108) in the Dallas Heart Study, another American non-referral population (n=3450) including also women. (48)

In line to these American population studies, the incidence of pHPT was 0.73% among 3014 men aged 69 to 81 years enrolled in the MrOS-Sweden cohort.(49)

In fact, Sharma and colleagues performed a screening study among patients with a diagnosis of urolithiasis. In 381 patients the prevalence of clinically and biochemically confirmed pHPT was 5% (n=19) which exceeds the prevalence found in the general population.(50) Parks and colleagues found the same prevalence in another cohort of patients with nephrolithiasis.(51) By contrast, a Korean insurance-claim databased analysis found only an incidence of 0.4%.(52)

In a Swedish study, the prevalence of pHPT among 167 postmenopausal women with a forearm fracture was 6.7% (n=8) and exceeded the pHPT prevalence in healthy postmenopausal women by the two-fold.(53)

In summary, depending on the population studied and the laboratory detection method used, the prevalence of pHPT ranges between 4 and 31 per 1000 (27 and 30 per 100 000 person-years), and pHPT still occurs more often in women.(4, 7, 54) PHPT occurs more commonly in sub-populations with increased pre-test probability such as in patients with urolithiasis or osteoporotic fracture.

10.3.3. Clinical presentation

As mentioned in the **Epidemiology chapter**, the classical signs and symptoms of hypercalcemic pHPT patients at diagnosis are resulting from both long-standing and often severe hypercalcemia and severe hyperparathyroidism and have formed the clinical triad of pHPT including bone disease, pancreatitis and nephrolithiasis, in German “Stein-, Bein- und Magenpein”. At present, the majority of patients is incidentally diagnosed by a laboratory constellation of hypercalcemia in concomitance with hyperparathyroidism, at a disease stage where they may still be asymptomatic and may not have signs of pHPT. Typical signs and symptoms of pHPT are summarized in the following.

Signs

Classical signs of pHPT can be referred to as target organ damage of either chronically elevated calcium or elevated PTH levels. In the present era of asymptomatic pHPT, vast efforts have been invested to assess whether early disease forms (asymptomatic pHPT, normocalcemic pHPT) may exhibit early

signs of target organ damage such as osteoporosis and may be candidates for parathyroidectomy.

Arterial hypertension and LV hypertrophy have been considered as signs of target of organ damage by some authors. However, they are explicitly not mentioned as specific complications of pHPT in the current International Guidelines for the Diagnosis of pHPT, due to inconclusive evidence.(30) Due to the high prevalence of arterial hypertension and LV hypertrophy in the general population, it may be difficult to decide on an individual basis, whether LV hypertrophy is related to pHPT or not, and to base an indication for parathyroidectomy solely on the presence of LV hypertrophy. Evidence on potential cardiovascular complications of pHPT is extensively summarized in the **Chapter on Cardiovascular disease in primary hyperparathyroidism.**

- Pancreatitis

Hypercalcemia accelerates trypsinogen degradation to trypsin in pancreatic cells which may predispose patients with pHPT to developing pancreatitis. In fact, patients with pHPT have a risk of pancreatitis that is said to exceed that of the general population by the 10- to 20-fold.(55, 56) Overall, pancreatitis is a rare complication of pHPT, but patients with pancreatitis and concomitant hypercalcemia should be tested for pHPT.

- Osteitis cystica fibrosa

Osteitis cystica fibrosa (also known as Recklinghausen's disease) is a radiological diagnosis based on typical findings such as “demineralized skeleton, salt-and-pepper appearance of the skull, radiological loss of the distal 1/3 of the clavicle, subperiosteal resorption of the phalanges, bone cysts, and brown tumors” as summarized by Silverberg and colleagues.(57) Pathophysiologically, it is a late consequence of extensive bone resorption due to chronic osteoclast activation by PTH. It is almost exclusively found in patients with pHPT and is rarely diagnosed in patients with parathyroid carcinoma.

- Urolithiasis

Patients with pHPT are at increased risk of stone formation in the urinary tract and can present with nephrocalcinosis, nephrolithiasis or ureterolithiasis.(58) In fact, urolithiasis is a common complication of pHPT. Hypercalcemia leads to hypercalciuria which is commonly appreciated as the crucial feature in pHPT to cause urolithiasis. This concept is however contrasted by a recent retrospective study showing a high prevalence of nephrolithiasis of 36% in patients with normocalcemic disease.(59) In fact, the risk of urolithiasis in normocalcemic pHPT has not yet been well described. Interestingly, even asymptomatic pHPT patients are at increased risk of urolithiasis.(60) Evaluation of the individual risk of urolithiasis is therefore a hallmark of pHPT-specific diagnostic work-up, and current guidelines recommend early surgery in high-risk candidates.(30)

- Osteoporosis

Patients with osteoporosis may present with back pain, but also with height loss due to vertebral fractures or with a history of osteoporotic fractures. Bone resorption in pHPT is mainly stimulated at sites with predominantly cortical bone such as distal forearm. In Western countries, osteoporosis is the most common sign encountered in patients diagnosed with pHPT.

Symptoms

As with signs of pHPT, the occurrence rate and the severity of pHPT-specific symptoms is related with disease severity. Yet, patients may be symptomatic, even when signs of pHPT are absent. In selected patients, parathyroidectomy can be beneficial in symptomatic patients even when they do not present with signs of pHPT-related target organ damage.(30, 57)

- Neurocognitive and psychiatric disorder

Calcium concentrations in cerebrospinal fluid correlate well with circulating calcium concentrations leading to higher levels in hypercalcemic pHPT than in normocalcemic pHPT.(61) More so, 1 of 5 patients with pHPT has

psychiatric disorders including fatiguability, lassitude, failing memory, concentration difficulties, sadness, and inner tension.

This can lead to impairment in cognitive performance (eg. retentiveness and concentration) which can improve after parathyroidectomy.(62)

10.3.4. Treatment of primary hyperparathyroidism

The only curative treatment of pHPT is surgical treatment. Patients with pHPT who are symptomatic are recommended to undergo surgery. Typical symptoms are summarized in the chapter above. However, the diagnosis of pHPT is often made incidentally, in patients without overt symptoms. In this growing subgroup also comprising patients with normocalcemic pHPT, four indications for surgery have been defined. They include age above 50 years, severe pHPT as defined by levels of total calcium more than 0.25 mmol/l above the local upper reference range, presence of osteoporosis at any site and high risk of/presence of nephrolithiasis (see **Table 2**). If one of these criteria is present, surgery is recommended.

In patients with contraindications to surgery (such as high intraoperative risk due to comorbidities), who are not willing to undergo surgery or who had unsuccessful parathyroidectomy, a conservative treatment approach can be applied using drugs. In fact, cinacalcet has been shown to significantly reduce calcium levels in patients with pHPT: In a double-blind multi-center randomized, placebo-controlled trial, 67 patients with pHPT were allocated to treatment with cinacalcet or placebo over 28 weeks. Both PTH and calcium levels were significantly lowered and normocalcemia was achieved in 76% of cinacalcet treated patients compared to 0% in the placebo group.(63) However, in another study cinacalcet did not improve BMD so that at the moment it is only considered a symptomatic therapy.(64)

Interestingly, in another randomized placebo-controlled trial (RCT) enrolling 46 patients with pHPT who were already scheduled for parathyroidectomy, vitamin D supplementation over a period of 26 weeks significantly decreased PTH and also improved markers of bone resorption and BMD.(65)

- 1) Age <50 years.
- 2) Serum calcium > 1 mg/dL or >0.25 mmol/L of the upper limit of the reference interval for total calcium and >0.12 mmol/L for Ca²⁺.
- 3) BMD T-score ≤-2.5 at the lumbar spine, femoral neck, the total hip, or the 1/3 radius for postmenopausal women or males >50 yrs. A prevalent low-energy fracture (i.e., in the spine) is also considered an indication for surgery, which requires a routine X-ray of the thoracic and lumbar spine (or vertebral fracture assessment by DXA).
- 4) A glomerular filtration rate (GFR) of <60 ml/min. Further evaluation of asymptomatic patients with renal imaging (X-ray, CT or ultrasound) in order to detect silent kidney stones or nephrocalcinosis is advised [2]. A complete urinary stone risk profile should be performed in those individuals whose urinary calcium excretion is > 400 mg/day. If stone(s), nephrocalcinosis, or high stone risk is determined, surgery should be recommended.

Table 2: Indications for surgery for the treatment of asymptomatic primary hyperparathyroidism according to Canadian and International recommendations.(1)

Cited from Khan AA, Hanley DA, Rizzoli R, Bollerslev J, Young JE, Rejnmark L, et al. Primary hyperparathyroidism: review and recommendations on evaluation, diagnosis, and management. A Canadian and international consensus. *Osteoporos Int.* 2017 Jan;28(1):1-19

<https://link.springer.com/article/10.1007%2Fs00198-016-3716-2>. The journal has open access format and no permission for reuse in a thesis is necessary.

10.3.5. Bone disease in primary hyperparathyroidism

Bone disease in pHPT is characterized as a state of high turnover disorder. More precisely, chronic elevation of PTH, such as in pHPT, leads to activation of osteoclasts rather than of osteoblasts, and thereby shifts bone remodeling towards a catabolic state. This translates to a higher risk of osteoporosis particularly at sites with predominantly cortical bone such as the distal radius (66), although several studies also indicate higher risk of osteoporosis and fractures at predominantly trabecular bone such as the lumbar spine.

Bone formation as well as bone resorption markers are in the high normal range or increased and decrease shortly after parathyroidectomy.(67–69) Various studies consistently document the increased risk of reduced BMD and fractures in pHPT. As summarized in a review by Costa and Bilezikian, biochemical markers of bone metabolism are a useful tool to monitor bone involvement in pHPT.(70)

Kersch-Schindl and colleagues comprehensively documented a significant decrease of alkaline phosphatase, OC and CTX after parathyroidectomy in patients with pHPT. Concomitantly, BMD at the lumbar spine increased one year after surgery while at the femoral neck a significant improvement of BMD could not be observed.(67)

Thorsen et al reported on a beneficial effect of parathyroidectomy on BALP and osteocalcin as well as BMD at the spine, femoral neck, Ward's triangle and trochanter.(68)

Bollerslev et al. documented that in patients with mild pHPT osteocalcin and CTX-1 decreased by 35% with surgery, followed by a significant increase in BMD at the spine (2.7%; $P < 0.01$) and femoral neck (1.1%; $P < 0.02$) compared with the pHPT group without surgery after a follow-up of two years.(71)

In the Swedish MrOS study, men with pHPT had a lower bone mineral density (BMD) than men without pHPT, both at the total hip and at the femoral neck.(49)

In a retrospective analysis of the Danish National Patient Register of years 2005 to 2015, 588 patients with pHPT and available X-ray of the spine were identified of whom 122 (21%) had vertebral fractures. PHPT patients with fractures had lower BMD both at the total hip and at the forearm than pHPT patients without fractures. However, comparing pHPT patients with fractures with age- and sex-matched osteoporotic patients who had vertebral fractures, the pHPT patients had higher BMD at both sites. Interestingly, the severity of pHPT was not associated with the presence of fractures.(72)

By contrast, in another pHPT longitudinal study by Sitges-Serra and colleagues, PTH-value was higher in patients with osteoporosis than in osteopenic patients or those with normal BMD.(73)

Rao et al. found in a randomized controlled clinical trial that pHPT patients without surgery lost BMD at both the femoral neck (-0.4%/yr, P = 0.117) and the total hip (-0.6%/yr, P = 0.007), respectively; This was accompanied by a significant decline of quality-of-life scores (measured by a 36-item short-form health survey).(74)

Similarly, Rubin et al. found progression of PHTH in one third of the patients without surgery and noted a significant decrease of cortical bone density in the majority of patients.(75)

Vestergaard et al. assessed fracture rates in 654 pHPT patients before and after parathyroidectomy. Fracture risk was 1.8-fold increased before surgery, when compared to an age- and sex-matched patient register and returned to normal after parathyroidectomy.(76)

Bandeira and colleagues aimed to describe the prevalence of osteoporosis at sites with predominantly cortical bone, as measured by dual-energy X-ray absorptiometry (DXA). They included patients with pHPT and measured BMD at the lumbar spine, femoral neck and 1/3 radius. Subgrouping their cohort into asymptomatic patients, patients with renal stones and patients with osteitis fibrosa cystica, they found that more than 85% of patients in the latter group had osteoporosis at least at one site (lumbar spine 100%, femoral neck 86%, 1/3 radius 86%). Even asymptomatic patients had high percentages of osteoporosis (lumbar spine 48%, femoral neck 20%, 1/3 radius 71%).(77)

10.3.6. Cardiovascular disease in primary hyperparathyroidism

Mechanisms

The PTH1R receptor is expressed in many tissues, including vascular smooth-muscle cells (VSMCs), vascular endothelial cells and cardiomyocytes. As a consequence, both high concentrations of serum calcium and PTH, the pathognomonic features of PHPT, affect the cardiovascular system.

Experimental and animal studies showed that PTH exerts pro-hypertrophic effects on cardiomyocytes, besides its role in calcium and phosphate homeostasis: PTH

directly stimulates intracellular calcium uptake in cardiomyocytes and thereby reduces the activity of mitochondrial creatine kinase (CK). (78, 79) Reduced CK activity is a key feature of chronic heart failure.(80) Likewise, upregulation of aldosterone increases calcium load in cardiomyocytes and induces markers of myocardial remodeling which can be attenuated by parathyroidectomy suggesting that PTH plays a permissive role for aldosterone-induced myocardial remodeling. (81) Moreover, PTH increases protein content in cardiomyocytes and thereby resembles noradrenaline mediated effects.(82) In fact, PTH stimulates the secretion of stress hormones from cardiomyocytes and thereby contributes to the activation of the cardiac intrinsic sympathetic system which is a key feature in the pathogenesis of heart failure and arrhythmias.(83–86) In rats with pressure-induced left ventricular (LV) hypertrophy and heart failure, PTH application led to septal hypertrophy and enlarged cardiac dimensions.(87) Moreover, PTH exerted positive inotropic effects on cardiomyocytes in an experimental setting. It must be noted that this effect could only be observed in the presence low calcium concentrations.(88) Suggested pathways of the interplay between PTH and the renin–angiotensin–aldosterone system in the setting of PTH excess are illustrated in **Figure 4**.

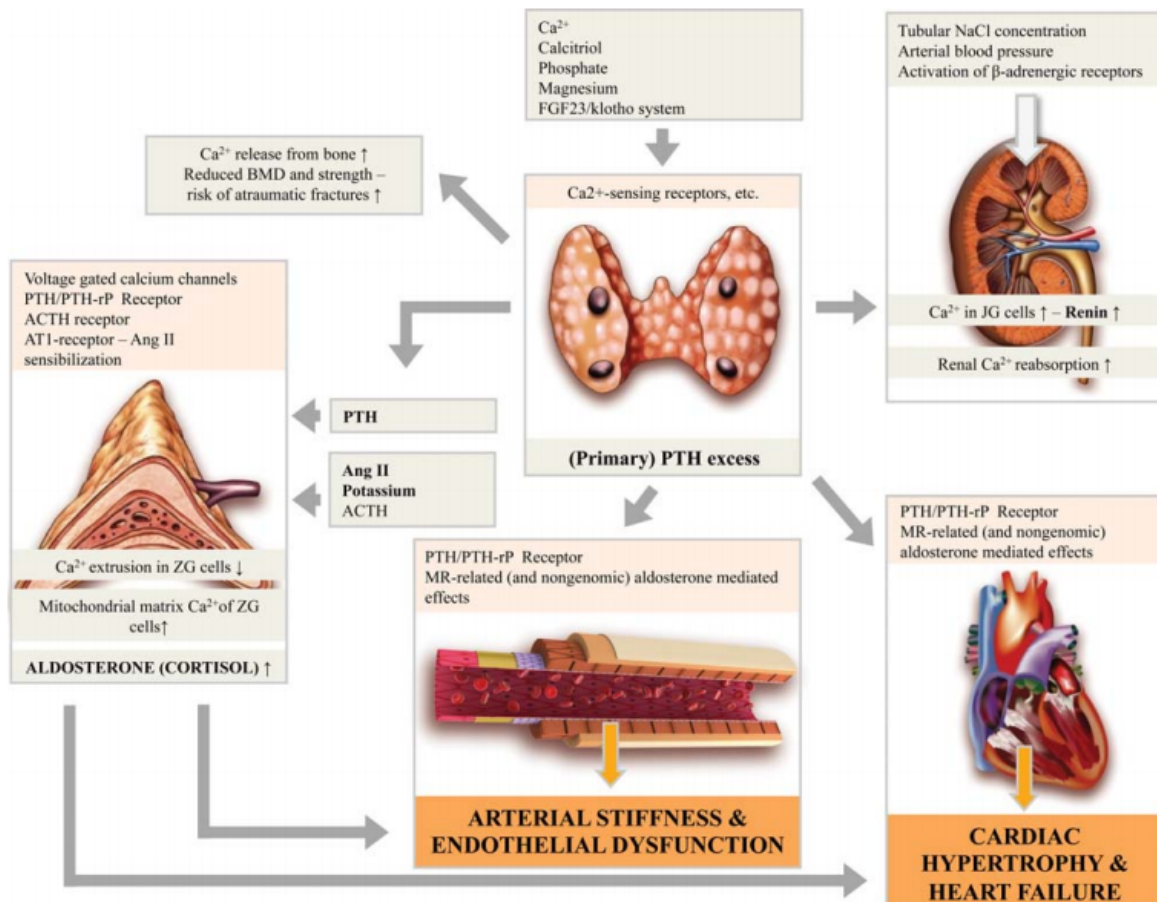

Figure 4: Suggested pathways of the interplay between PTH and the renin-angiotensin-aldosterone system in the setting of PTH excess.(89)

PTH (excess) increases circulating ionized Ca^{2+} (via increasing Ca^{2+} release from bone and decreasing renal Ca^{2+} excretion). PTH is suggested to stimulate renin synthesis by increasing calcium levels in JG cells. Renal renin synthesis is further controlled by tubular sodium concentration, arterial blood pressure, and the sympathetic nervous system. Extracellular potassium and angiotensin II are major stimulators of aldosterone synthesis in the adrenal glands. Both factors interact with voltage-gated calcium channels and depolarize the zona glomerulosa cells which result in elevated intracellular calcium levels. PTH might also directly stimulate aldosterone synthesis by binding to the PTH/PTH-rP receptor, voltage-gated calcium channels, and the adrenocorticotropic hormone receptor, which results in increased mitochondrial Ca^{2+} levels. In addition, PTH is suggested to increase sensitization towards angiotensin II which by itself reduces cellular calcium extrusion through activating $\text{Na}^{+}/\text{Ca}^{2+}$ exchangers in zona glomerulosa cells. PTH contributes to the development of arterial stiffness, arterial hypertension, and cardiac hypertrophy via binding to the PTH/PTH-rP receptor, which is expressed in vascular smooth muscle cells and cardiomyocytes. In addition, aldosterone, i.e. relative aldosterone excess, exerts genomic (by binding to the MR), and non-genomic profibrotic and proinflammatory effects on blood vessels and the myocardium.(89)

Abbreviations:

BMD, bone mineral density; PTH (rP), parathyroid hormone (related peptide); ACTH, adrenocorticotropic hormone; ANG II, angiotensin II; ZG, zona

glomerulosa; JG, juxtaglomerular; MR, mineralocorticoid receptor; ACE, angiotensin converting enzymes; AT1-receptor, angiotensin II type 1 receptor.

Cited from Tomaschitz A, Ritz E, Pieske B, Fahrleitner-Pammer A, Kienreich K, et al. Aldosterone and parathyroid hormone: a precarious couple for cardiovascular disease. *Cardiovasc Res*. 2012 Apr 1;94(1):10-9. doi: 10.1093/cvr/cvs092

<https://academic.oup.com/cardiovascres/article/94/1/10/272409>. Permission for reuse in a thesis obtained from Oxford University Press.

Cardiovascular outcomes

The relationship between increased PTH concentrations and cardiovascular disease and events has been confirmed in several clinical studies including healthy subjects, but also among patient cohorts with specific underlying risk profiles, such as patients with chronic kidney disease, chronic heart failure or subjects who were referred to coronary angiography.

In the population-based Tromsø study including 3570 normocalcemic participants, circulating PTH concentrations predicted coronary heart disease.(90)

In the LURIC study, 3232 patients referred to coronary angiography were stratified by quartiles of serum PTH. Those within the 4th quartile were at significantly higher risk of cardiovascular mortality when compared to those within the 1st PTH quartile, even after adjustment for important confounding parameters, adjusted HRs: 2.02 (1.55-2.63).(23)

Increased PTH concentrations independently predict hospitalizations due to heart failure in the general population (91), in patients with chronic heart failure (92) and in elderly frail subjects with secondary hyperparathyroidism.(93) PTH correlated with pulmonary capillary wedge pressure and NT-proBNP in chronic heart failure patients.(94, 95) Also in patients with chronic kidney failure, secondary hyperparathyroidism and heart failure, parathyroidectomy was associated with an improvement in LV ejection fraction.(96, 97) High PTH has also been reported to predict heart failure with preserved ejection fraction.(98)

In addition, in 1578 Danish men and women with PHPT an increased risk of cerebrovascular disease was documented.(99) Various clinical studies indicated

an increased cardiovascular risk in patients with a diagnosis of pHPT, although some studies reported conflicting results, particularly in asymptomatic or normocalcaemic pHPT patients, i.e. patients with mild or moderate disease severity.

In patients with pHPT the risk of cardiovascular death is 2-3 fold higher than in the general population and PTH is an independent predictor of mortality. (Yu et al. 2010; Nilsson et al. 2002) In 100 patients with pHPT who were case-matched with 50 healthy controls the authors could demonstrate impaired coronary perfusion which was improved after parathyroidectomy.(100)

Several Scandinavian studies found an increased risk of cardiovascular mortality in patients with severe and moderately severe PHPT.(101–104) Because increased cardiovascular risk appeared to persist long after parathyroidectomy, it was hypothesized that PTH may cause persisting damage to the cardiovascular system.(105) Among 10,995 Swedish patients who had undergone parathyroidectomy the long-term mortality risk was significantly increased which was blunted in those enrolled later in the study or in participants with comparably low calcium levels. (106)

Regarding asymptomatic pHPT, evidence for higher (total and cardiovascular) mortality is controversial and inconsistent. This is most likely due to (1) the heterogeneity of the cohorts with some including more severe and some including less severe phenotypes and (2) the short follow-up duration. For example, Wermers et al. observed no relationship between mild PHPT and risk of overall death in unselected patients in the community, whereas higher maximal serum calcium levels were an independent predictor of mortality.(107) On the contrary, Yu et al. impressively showed higher risks of all-cause mortality, fatal and nonfatal CVD as well as of renal failure and renal stones in patients with asymptomatic PHPT.(108)

Cardiac structure and function and arterial hypertension

Arterial hypertension might be an important pre-requisite for the PTH related risks of cardiovascular disease and mortality. For instance, in 845 patients with

asymptomatic PHTH (and preserved kidney function) mortality was 50% higher in hypertensive hyperparathyroid patients compared to normotensive patients.(109)

Several studies evaluated the risk of arterial hypertension in patients with (mild) PHPT. In general, hypertension is frequently seen in association with pHPT. In a historical work from 1972 by Rosenthal and Roy, arterial hypertension was already well recognized as a complication of pHPT, although the authors were unclear about the specific causes. Nevertheless, they recommended screening for pHPT in patients with arterial hypertension as they considered pHPT a reversible cause. (110) In a prospective case-control study, 48 patients with mild pHPT and no cardiovascular risk factor were longitudinally studied before and after parathyroidectomy, with a focus on markers of arterial disease. Although the authors did not find evidence of arterial structural disease as measured for instance by intima media thickness of the carotids or augmentation index, pHPT patients had higher blood pressure levels and higher pulse wave velocity than controls, both of which were reduced one year after parathyroidectomy.(111) Other studies including patients with normocalcemic pHPT found similar results. (112, 113)

Markedly increased blood pressure (BP) levels were reported in women with high PTH levels. In a case-control study BP was significantly higher in female patients with hyperparathyroidism compared to a control group (systolic BP 146.7 +/- 18.6 vs. 137.4 +/- 23.0 mmHg [P < 0.05] and diastolic BP 88.1 +/- 11.8 vs. 82.2 +/- 10.6 mmHg [P < 0.05]).(114)

In a study including hypertensive patients, elevated PTH was associated with non-dipping status, even after adjustment for confounding parameters.(115) Also in patients with pHPT and arterial hypertension who were matched with hypertensive subjects without pHPT, non-dipping status was more prevalent.(116) In subjects with secondary hyperparathyroidism, PTH was significantly and independently correlated with nighttime BP, see **Figure 5**.(117)

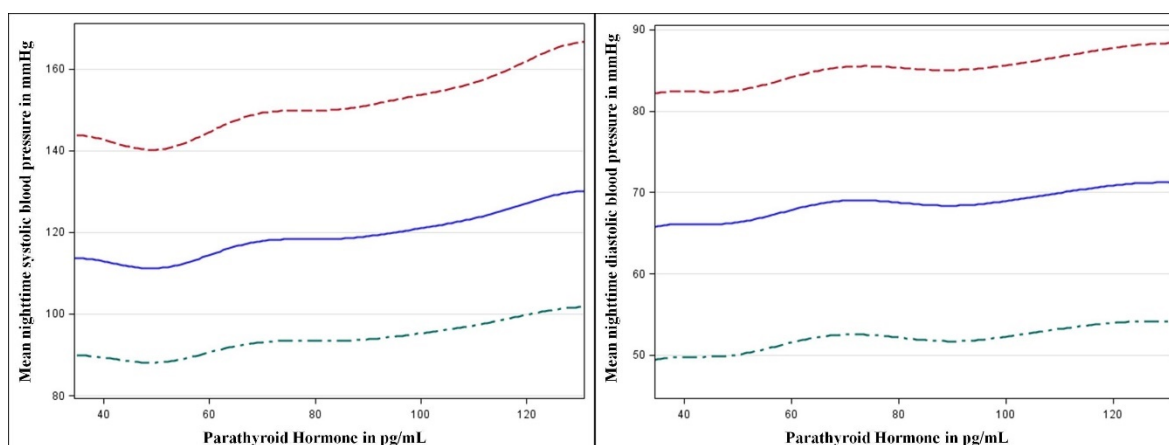

Figure 5: Relationship between plasma parathyroid hormone and mean nocturnal systolic blood pressure in a multivariate model (A). Relationship between plasma parathyroid hormone and mean nocturnal diastolic blood pressure in a multivariate model (B). (118)

Cited from Verheyen ND, Kienreich K, Gaksch M, van Ballegooijen AJ, Grüber MR, et al. Plasma Parathyroid Hormone Is Independently Related to Nocturnal Blood Pressure in Hypertensive Patients: The Styrian Hypertension Study. *J Clin Hypertens (Greenwich)* 2016; 18(6):543–50;

<https://onlinelibrary.wiley.com/doi/full/10.1111/jch.12710>. The journal has open access format and no permission for reuse in a thesis is necessary.

With this in line, a reduction of mean daytime systolic BP one year after parathyroidectomy has been reported, although also conflicting results have been published.(118, 119)

The pathophysiological consequence of arterial hypertension is diastolic dysfunction due to cardiac remodeling and LV hypertrophy. In fact, some studies reported on impaired diastolic function in pHPT patients compared with healthy controls, while arbitrary results have been published with regard to systolic function.(120, 121) Various further studies pointed to a higher prevalence of LV dysfunction and myocardial ischemia with a possible increased risk of life-threatening arrhythmia in patients with pHPT compared to healthy controls.(122–125) Other studies observed a high prevalence of LV hypertrophy, calcification in the myocardium, and/or aortic and mitral valve calcification in patients with PHPT. (126)

Analysing the US American Nationwide Inpatient Sample 2009-2010 database, Kalla et al included 37.922 patients with hospital admissions in their study of whom 0.1% had pHPT. After adjustment for age and sex, the rates of heart failure and of coronary artery disease were similar between the pHPT population and the non-pHPT population. Yet, pHPT was associated with an increased risk of arterial hypertension, even after multivariate adjustment.(127)

In one recent meta-analysis, Bae and colleagues included 14 studies with reported echo data before and after parathyroidectomy. While overall quality of the included studies was partly moderate and there was high heterogeneity between studies, they did not find significant changes in LV systolic or diastolic function after parathyroidectomy. A non-significant trend towards reduction of LV mass after parathyroidectomy was reported.(128)

Although one other recent meta-analysis suggested a reversal of LV hypertrophy after parathyroidectomy in patients with operated pHPT, the presence of arterial hypertension or of LV hypertrophy in patients with pHPT is currently not an indication for parathyroidectomy.(129)

Taken together, overwhelming evidence from clinical studies points towards adverse effects of PTH on blood pressure regulation so that pHPT patients are at increased risk of arterial hypertension. The effects, however, on target organs are not well-understood which is most likely the result of small sample sizes and the lack of randomized controlled trials to reveal effects of parathyroidectomy on cardiac function parameters. It is however well established that patients with pHPT are exposed to a higher cardiovascular mortality risk which increases with the severity of pHPT.

10.3.7. Interaction between parathyroid hormone and aldosterone in primary hyperparathyroidism

In 1980 a case of a 60y year-old lady was reported who had pHPT and primary aldosteronism and was referred for parathyroidectomy. After surgery, a decline of plasma aldosterone and BP levels was observed so that a mechanistic interplay between both hormones and direct or indirect causal role of PTH in the pathogenesis of aldosteronism was suggested.(130)

Pacifici et al. observed significantly decreased plasma aldosterone levels in 16 patients with pHPT after parathyroidectomy, whereas the decrease in aldosterone levels was significant only in the normotensive group. (131) The results indicated that surgical therapy for hyperparathyroidism lowers serum calcium and BP and is associated with a decrease in the excretion of adrenal steroid metabolites. With this in line, Jespersen et al. reported a significant decline of aldosterone levels (and unaltered angiotensin II) after parathyroidectomy in patients with pHPT.(132) Similarly, Gennari et al. observed normalization of serum calcium and PHT levels were reduced to normal values in all patients. BP, plasma renin activity and plasma aldosterone levels turned normal in 8 of 10 hypertensive patients after parathyroidectomy.(133) Further study noted significantly decreased plasma aldosterone and renin activity in patients with pHPT after parathyroidectomy, but the changes of the renin-aldosterone system after surgery did not correlate with the changes in serum calcium levels.(134, 135)

Fallo et al. compared the effect of angiotensin II infusion on aldosterone concentrations in patients with pHPT before and after parathyroidectomy. Plasma aldosterone and renin activity were normal both before and after the parathyroidectomy. The increase in the aldosterone concentrations from baseline at each time point of the angiotensin II infusion was significantly higher in hyperparathyroid patients before than after surgery, and significantly higher than in healthy controls. The authors concluded that high levels of extracellular calcium or PTH, or both, might play a mediating role in the aldosterone hyperresponsiveness to angiotensin II in patients with pHPT.(136)

In 2009 Brunaud et al. provided novel evidence to the interrelationship between PTH and aldosterone by investigating 134 patients with PHPT. Preoperative serum aldosterone were significantly higher in patients with PTH levels > 127 ng/L compared to those with PTH < 127 ng/L ($p=0.019$) independent of ongoing antihypertensive medication.(137) Importantly, preoperative PTH levels but not calcium levels remained an independent predictor of abnormally elevated preoperative plasma aldosterone levels. Three months after surgery overall no significant correlation was observed between postoperative PTH and aldosterone levels.(137)

11. Research question

In view of the documented reciprocal interaction between aldosterone and PTH, and in light of the potential impact of this hormone interaction on target organ damage, additional studies are needed to evaluate the effects of MR antagonists (MRA) on PTH concentration, cardiovascular and bone health in patients with pHPT.

We, therefore, performed a randomized controlled trial in patients with pHPT to address the question whether the MRA eplerenone lowers plasma intact PTH (iPTH) levels, measured by two different second generation assays, and exerts a beneficial effect on cardiovascular and bone health.

12. Material and Methods

12.1. Study design (138, 139)

The Effect of Eplerenone on Parathyroid Hormone Levels in Patients with Primary Hyperparathyroidism (EPATH) Trial is a single-center, randomized, double-blind, parallel- group, placebo-controlled trial conducted at the Department of Cardiology, Medical University of Graz, Austria. Eligible women and men were randomized in a doubleblinded fashion to MRA (eplerenone; 25 mg/day for 4 weeks, then uptitrated to 50 mg/day for 4 weeks) or matching placebo (one tablet daily for 4 weeks, then uptitrated daily for 4 weeks). Study participants were instructed to take the study drug in the morning, including days of study visit. Follow-up visits were scheduled at 1, 4, 5, and 8 weeks until completion of the study. The study flowchart is depicted in **Figure 6**.

Renal function and plasma potassium levels were measured at baseline, 1 week after the initiation of the study treatment, at all scheduled clinical visits and after any change of dose (after 5 weeks). At completion of the final study visit, all of the examinations performed at baseline were repeated. If at any time during the study process the plasma potassium concentration was more than 5.0 mmol/l, the study medication was downtitrated, and it was discontinued in participants with plasma potassium concentration at least 5.5 mmol/l. The study drug was further discontinued in case of a rise of serum creatinine at least 3.0 mg/dl or estimated glomerular filtration rate (eGFR) less than 30 ml/min per 1.73m² (or downtitrated in case of eGFR values between 30 and 49 ml/min per 1.73m²), anaphylactic reactions or intolerance because of eplerenone intake, requirement for an open-label use of eplerenone or potassium-sparing diuretics, or formal withdrawal of the consent.

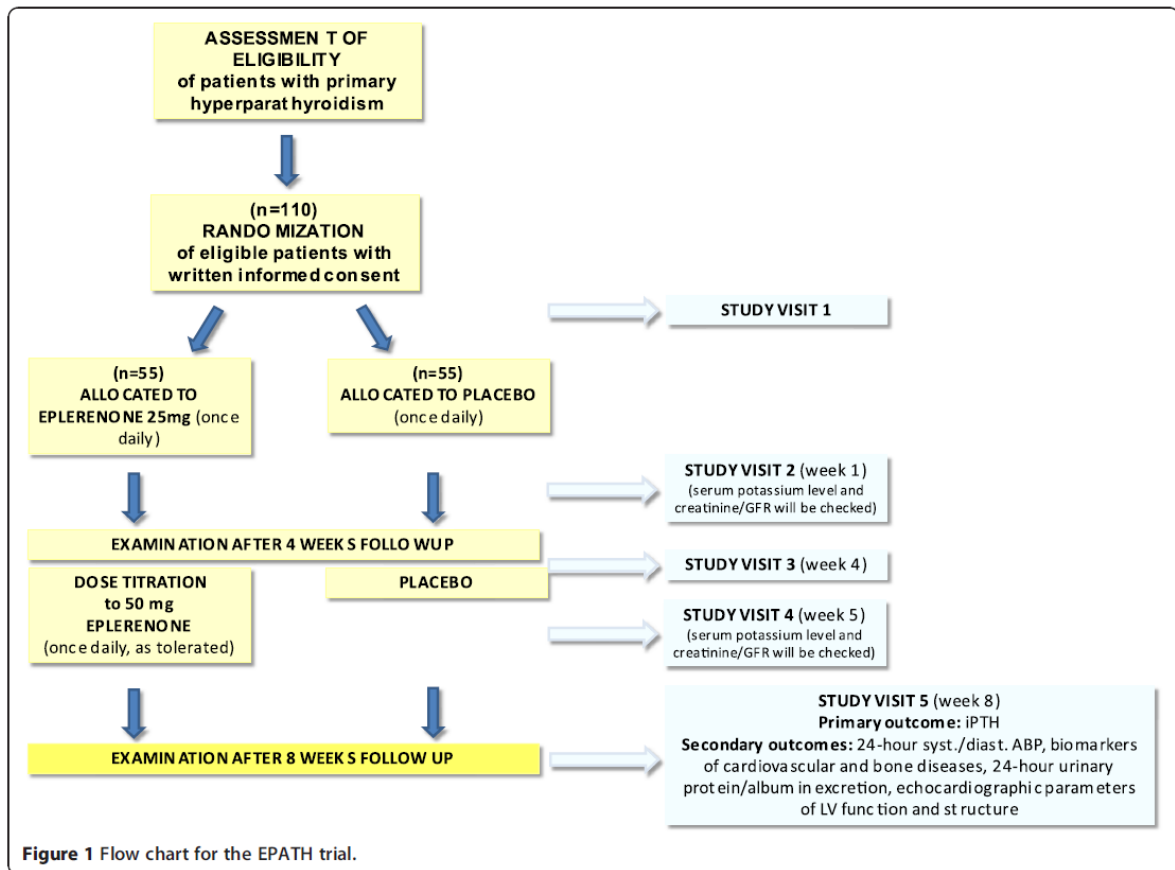

Figure 6: Flowchart of the EPATH trial. (138)

Cited from Tomaschitz A, Fahrleitner-Pammer A, Pieske B, Verheyen N, Amrein K, et al. Effect of eplerenone on parathyroid hormone levels in patients with primary hyperparathyroidism: a randomized, double-blind, placebo-controlled trial. *BMC Endocr Disord.* 2012 Sep 13;12

<https://bmcendocrdisord.biomedcentral.com/articles/10.1186/1472-6823-12-19>. The journal has open access format and no permission for reuse in a thesis is necessary.

Randomization was performed using a web-based participant randomization service for clinical trials (Randomizer, Institute for Medical Informatics, Statistics and Documentation, Medical University of Graz, Graz, Austria). Randomization was performed in a 1:1 ratio, by minimization with treatment probability 0.9 and was stratified according to sex (men or women) and indication of parathyroidectomy (yes or no) as judged by the clinical investigator.

All patients, the investigator team, and individuals performing the assessments remained blinded to the identity of treatment until after database lock. Eplerenone

and matching placebo were provided by Pfizer (Pfizer Inc., New York, New York, USA). Quality control, packaging, labeling, and dispensing of the study drug were performed by the Medical Dispensary for Research at the Medical University of Graz. The trial was designed and implemented by the principal investigators. The publication of this trial adheres to the Consolidated Standards of Reporting Trials (CONSORT) 2010 statement. The trial was registered at ISRCTN (ISRCTN33941607 DOI 10.1186/ISRCTN33941607). The study was performed in accordance with the Good Clinical Practice guidelines and local and national regulations and the Declaration of Helsinki. The study (EudraCT number: 2011–005683–21) has been approved by the Ethics Committee of the Medical University of Graz, Austria. Written informed consent was obtained from each participant.

12.2. Study funding (138, 139)

The EPATH Trial was supported by Pfizer Inc. (study drug and placebo), the Austrian National Bank Jubilaeumsfond (N8: 14621) and the Austrian Society of Bone and Mineral Research (Felix-Bronner Grant 2014, Project Prize 2014).

12.3. Participants (138, 139)

Participants were men and women of at least 18 years of age with pHPT. PHPT was assured based on laboratory measurements on the day of the screening visit and was defined as hypercalcemic pHPT (albumin-adjusted plasma calcium >2.55mmol/l or ionized plasma calcium >1.35mmol/l or regular use of cinacalcet for hypercalcemia) and inappropriately high iPTH (iPTH_{Roche}>46 pg/ml) or as normocalcemic pHPT (iPTH_{Roche}>65 pg/ml and albumin-adjusted plasma calcium above the median of the reference range (>2.35mmol/l) and plasma ionized calcium within normal ranges in the absence of chronic kidney disease (eGFR>40 ml/min per 1.73m²) and 25-hydroxyvitamin D [25(OH)D] deficiency [25(OH)D_20 ng/dl] as potential causes for secondary HPT and no regular use of cinacalcet. (140–142) We chose 2.55mmol/l as the upper range of normal calcium levels, because this is the recommended cut-off of the calcium assay we used.

Those patients with pHPT and in whom surgery was indicated but not recommended because of patient and/or physician preference or perceived medical contraindications were enrolled in addition to those not fulfilling surgery criteria. We used a iPTH cutoff greater than 46 pg/ml to define inappropriately high iPTH in the presence of hypercalcemia referring to previous works by Souberbielle and colleagues (140) who defined normal iPTH ranges in elderly and 25(OH)D sufficient individuals using a comparable PTH assay. Although there are no direct comparison studies in patients with pHPT between the PTH assay we used and the Nichols Allegro assay used by Souberbielle, comparison studies in hemodialysis patients indicated a good correlation between the two assays. (172) In that study the Roche iPTH we used showed on average one third lower levels when compared to the Nichols Allegro assay. In brief, the main inclusion criteria comprised 25(OH)D levels at least 20 ng/dl (multiply by 2.496 to convert ng/ml to nmol/l); eGFR (according to the CKD-EPI formula) more than 50 ml/min; and plasma potassium 5.0 mEq/l (mmol/l) or less at baseline.

Exclusion criteria were pregnancy or lactating women, acute coronary syndrome or cerebrovascular event in the previous 2 weeks, drug intake as part of another clinical study 4 weeks before enrollment into the EPATH Trial and/or during the active study period, chemotherapy or radiation therapy, intolerance to eplerenone or any ingredient occurring in eplerenone, severe acute or chronic liver diseases (Child–Pugh class C), concurrent intake of potassium-sparing drugs (e.g. diuretics such as amiloride and triamterene) or CPY3A4-inhibitors and ongoing potassium supplementation.

Patients were informed about the EPATH Trial either by a conversation in the outpatient clinic or by a telephone call. There was no additional specific advertisement for the trial. Participants were recruited from the outpatient clinics at the Department of Cardiology and the Department of Internal Medicine, Division of Endocrinology and Metabolism, Medical University of Graz, Graz, Austria. The study took place at the outpatient clinic at the Department of Cardiology from December 2012 to February 2015.

12.4. Intervention (138, 139, 143)

12.4.1. Primary outcome measure

The primary outcome measure was the between group difference in plasma iPTH concentrations measured by two different second generation assays.

12.4.2. Secondary outcome measures

Secondary outcome measures were between group differences in 24-h ambulatory systolic BP and diastolic BP, N-terminal pro-brain B-type natriuretic peptide (NT-proBNP), 24-h urinary albumin and protein excretion, echocardiographic parameters related to systolic and diastolic function as well as cardiac dimensions (LV ejection fraction, E/e' ratio, LV end-diastolic/systolic pressure/volume/index, and LV posterior wall thickness) and markers of bone turnover, including markers of osteoclast activity (active isoform 5b of the tartrate-resistant acid phosphatase [TRAP], CTX and markers of osteoblast activity (P1NP, OC, BALP).

12.5. Measurements (138, 139, 143)

Blood samplings were performed during the morning (0700 to 1100 h) after an overnight fast. Before blood sampling, patients remained in the seated position for at least 10 min. Measurement of iPTH (pg/ml) was performed immediately after blood sampling by electrochemiluminescence immunoassay 'ECLIA' (Elecsys immunoassay analyzer, Cobas; Roche Diagnostics GmbH, Mannheim, Germany). The Elecsys assay for determining iPTH Roche employs a sandwich test principle in which a biotinylated monoclonal antibody reacts with the N-terminal fragment (amino acid regions 1–37) and a monoclonal antibody labeled with a ruthenium complex reacts with the C-terminal fragment (amino acid regions 38–84). The antibodies used in this assay are reactive with epitopes in the amino acid regions 26–32 and 37–42. Blood for iPTH Roche determinations was collected with standard EDTA plasma tubes and centrifuged within 5–10 min. The measuring range of the assay was 1.20 (lower detection limit) to 5000 pg/ml (maximum of the master curve), with a reference range of 15–65 pg/ml, and an interassay

coefficient of variation between 3.0 and 6.5% for iPTHRoche 26.7–261 pg/ml (conversion factors of iPTH: $\text{pg/ml} \times 0.106 = \text{pmol/l}$; and $\text{pmol/l} \times 9.43 = \text{pg/ml}$, respectively). Using one-time frozen (-80°C) blood samples, plasma iPTH Diasorin was determined by a chemiluminescent immunoassay (CLIA; DiaSorin Liaison, Stillwater, Minnesota, USA). The Liaison iPTH Gen II assay is a modified two-step, two-site sandwich assay that uses two goat polyclonal antibodies for capture and detection of iPTH Diasorin (measuring range: 3–1900 pg/ml; reference range: 14.5–87.1 pg/ml). Interassay coefficient of variation was 1.8–3.4% for iPTH Diasorin concentrations between 12.6 and 156.1 pg/ml. Cavalier et al. [19] demonstrated a reasonably good agreement of measured iPTH concentrations between the Roche Elecsys and Diasorin Liaison assays.

Quantitative photometrical determination of total calcium in lithium-heparin sample was performed on a cobas c 8000 modular analyzer (Roche, Inc., Mannheim, Germany) using a calcium Gen.2 300 test kit (Mat.-No. 05061482; Roche, Inc., Mannheim, Germany). Coefficients of variation for repeatability were 0.8% and 2.0% for high (4.46 mmol/L) and low (0.60 mmol/L) calcium concentrations in human plasma. Coefficients of variation for intermediate precision were 0.9% and 2.5% for high (4.46 mmol/L) and low (0.60 mmol/L) concentrations. Lower detection limit in human plasma was 0.2 mmol/L = 0.8 mg/dL. The reference range is 2.15 to 2.55 mmol/L according to the manufacturer's instructions.

Total calcium in plasma was corrected for hypoalbuminemia (serum albumin <4 g/dl) in mmol/l by using the formula: albumin-adjusted calcium [(reference range: 2.15–2.55 mmol/l or 8.6–10.2 mg/dl) = total plasma calcium + $0.2 \times (4 - \text{plasma albumin})$]. Serum 25(OH)D (in ng/ml) was determined using a ChemiLuminescence assay (IDS-iSYS 25-hydroxyvitamin D assay; Immunodiagnostic Systems Ltd., Boldon, UK) on an IDS-iSYS multidiscipline automated analyser, with an intra and interassay coefficient of variation of 6.2 and 11.6%, respectively. NT-proBNP was measured using an ElectroChemiLuminescence immunoassay (Roche Diagnostics) using an autoanalyser (Elecsys 2010).

A pre-specified volume of blood samples was centrifuged and filled into 1 mL aliquots and frozen at -80°C . Circulating concentrations of bone markers were

measured in serum that had been frozen to -80°C after blood sampling. Markers of osteoclast activity (TRAP in U/L, CTX in ng/mL) and osteoblast activity (P1NP in ng/mL, OC in ng/mL, BALP in $\mu\text{g/L}$) were determined from one-time frozen serum using Enzyme-Linked Immunosorbent Assays (Immunodiagnostic Systems Ltd., Boldon, UK). TRAP was measured manually, while the other four markers were quantified on an IDS-iSYS multi-discipline automated system. Intra- and interassay coefficients of variation (CV) are 3.2% to 9.6% and 5.5% to 9.5% for P1NP, 1.3% to 2.2% and 2.7% to 5.1% for OC, 2.6% to 6.5% and 3.7% to 6.4% for BALP, 1.7% to 3.0% and 2.5% to 10.9% for CTX, and 6.0 to 13.9% and 5.4 to 9.2% for TRAP.

Before unblinding, genetic testing for FHH was performed in five participants with a 24-h urinary calcium-to-creatinine clearance ratio of less than 0.015. (142) After analysis of common FHH causing mutations in genes of the calcium sensing receptor and AP2S1 one randomized participant with a FHH-causing mutation in the calcium sensing receptor (c.2777A>G) was post-hoc excluded from trial participation and from analyses and one additional individual was, therefore, recruited to adhere to the prespecified sample size of the study. The 24-h urine samples for the determination of urinary albumin, protein and calcium excretion were collected in parallel to the 24-h ABPM. All other parameters were determined by routine laboratory procedures. All other parameters were determined by routine laboratory procedures. A validated 24-h ABPM device (Mobil-O-Graph; I.E.M. GmbH, Stolberg, Germany) was used for the measurement of 24-h ambulatory systolic BP and diastolic BP. The circumference of the upper arm was measured in all patients to select the appropriate cuff for BP recordings. BP was recorded every 20 min during the day (0600 to 2200 h) and every 30 min during the night (2200 to 0600 h). ABPM was performed according to the recommendations of the European Society of Hypertension.

Echocardiographic examinations were performed with a Vivid 7 or Vivid 9 (GE Healthcare, Chalfont St Giles, UK). A standard operating procedure for obtaining all echocardiographic measurements was released before recruitment began, and all participating investigators were trained and certified by the core laboratory staff. Peak early filling velocities of the mitral septal and lateral ring (e' , in cm/s) were measured applying tissue Doppler imaging. Following international guidelines

averaged e' was generated according to the formula $e'_{\text{average}} = (e'_{\text{medial}} + e'_{\text{lateral}})/2$. (144) Transmitral peak velocities were measured by using continuous wave Doppler and placing the signal at the tips of the mitral leaflets. LV ejection fraction (LVEF) was calculated by Simpson biplane method of disks. (145) Other measures of LV structure were measured in accordance with international guidelines. (145) All echocardiographic data were reviewed and confirmed at a blinded core laboratory (Echocardiography Core Lab of the Department of Cardiology, Medical University of Graz, Austria). Analyses were performed by one single investigator who was blinded to individual participant data.

12.6. Sample size considerations (138, 139, 143)

We assumed that eplerenone administered once daily had an effect size of 10.0 pg/ml on PTH levels. Calculating with a two-sided alternative hypothesis, α of 0.05 and a power ($1-\beta$) of 80%, lead a sample size of 51 study participants per group. To compensate for an anticipated drop-out rate of 10% during the study we planned to enroll 55 patients per group.

12.7. Statistical methods (138, 139, 143)

Continuous data following a normal distribution are shown as means with SD and variables with a non-normal distribution are shown as medians with interquartile range. Categorical data are presented as percentages. Skewed variables were $\log(e)$ transformed before use in parametric statistical analyses. Group comparisons (eplerenone vs. placebo) at baseline were estimated by use of an unpaired Student's t test, Mann–Whitney U test, or Chi^2 test where appropriate.

Analyses of the outcome variables were performed according to the intention-to-treat principle with no data imputation and inclusion of all participants with baseline and follow-up values of the respective outcome variable. Analyses of covariance (ANCOVA) with adjustments for baseline values were used to test for differences in the outcome variables between the eplerenone and the placebo group at the follow-up visit. Not prespecified exploratory subgroup analyses were performed in patients with normocalcemic and hypercalcemic pHPT, respectively. In addition, not prespecified interaction analysis of corrected plasma calcium concentrations with the primary outcome parameter as well as not prespecified secondary

outcome analyses by calculating the effect of eplerenone on both corrected plasma calcium concentrations and 24-h urinary calcium excretion, respectively, have been performed.(138, 139, 143)

12.8. Cross-sectional analyses (143)

Correlations between marker of bone turnover and PAC, PRC, ARR and PTH were performed using Pearson correlation analysis. In case of a significant correlation, multivariate linear regression analyses were performed, with adjustment for age, sex, plasma PTH (for PAC, PRC, ARR), body mass index, ongoing osteoporosis treatment (yes/no), treatment with ACE inhibitor and treatment with angiotensin-receptor blocker. (143)

A P value below 0.05 was considered statistically significant. Statistical analyses were performed by using IBM SPSS Statistics for Windows, Version 21.0 (IBM Corp., Armonk. New York, USA).

13. Results – Findings (139, 143)

13.1. General (139)

Approximately 2900 patient records were reviewed. Overall, 330 persons were invited to participate in the study screening and 198 provided written informed consent. Of these, 155 patients were categorized as pHPT (normocalcemic: 42 [27.1%]; hypercalcemic: 113 [72.9%]). Over half of the subjects had a diagnosis of pHPT for more than 4 years prior to study inclusion. The participant flow through the study is shown in **Figure 7**.

One-hundred ten patients (79.1% women) with confirmed pHPT (normocalcemic: n=31 [28.2%]; hypercalcemic: n=79 [71.8%]) were randomized to MRA (n=54) or matching placebo (n=56). At randomization, surgical parathyroidectomy was indicated but neither scheduled nor intended in 48 (43.6%) participants and not indicated in all other participants.

Study participation was discontinued for 13 patients (11.8%): seven in the placebo group (12.5%) and six in the eplerenone group (11.1%). A total of 97 study participants (mean [SD] age: 67.5 ± 9.5 years; 78.4 % females; 27.8 % normocalcemic) completed the baseline and follow-up visits. The overall treatment period was 55 ± 5 days in the eplerenone and 56 ± 5 days in the placebo group. Study medication was returned by 48 participants in the eplerenone and by 49 participants in the placebo group. According to the remaining tablets in the boxes we estimated a compliance of 99.4 ± 0.1% in the eplerenone and 98.5 ± 0.04% in the placebo group.(139)

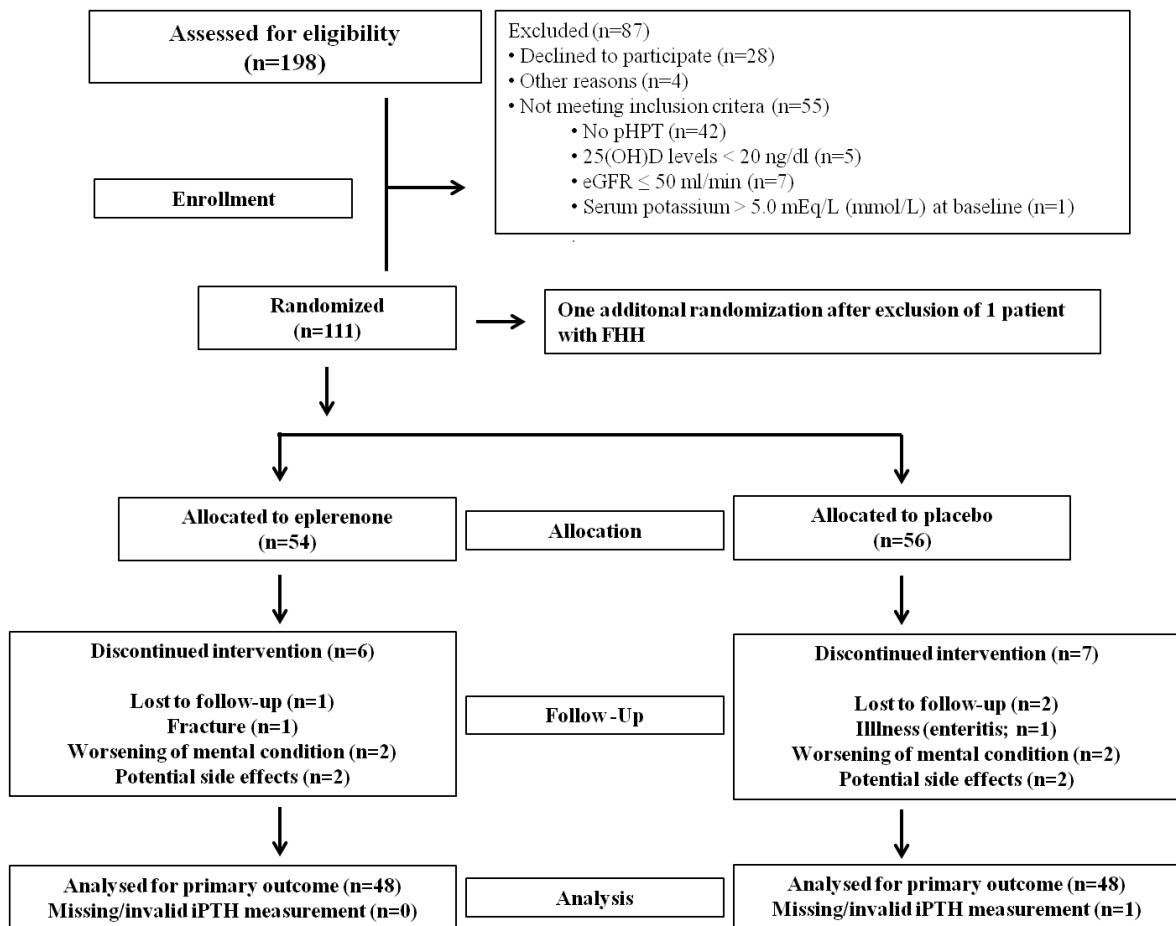

Figure 7: Flowchart showing the number of participants screened, excluded, randomized and analyzed for primary outcome.(139)

Abbreviations: pHPT, primary hyperparathyroidism; 25(OH)D, 25-hydroxyvitamin D; eGFR, estimated glomerular filtration rate; iPTH, intact parathyroid hormone

Cited from Tomaschitz A, Verheyen N, Meinitzer A, Pieske B, Belyavskiy E, Brussee H et al. Effect of eplerenone on parathyroid hormone levels in patients with primary hyperparathyroidism: results from the EPATH randomized, placebo-controlled trial. *J Hypertens* 2016; 34(7):1347–56;

https://journals.lww.com/jhypertension/Abstract/2016/07000/Effect_of_eplerenone_on_parathyroid_hormone_levels.17.aspx.
Permission for reuse in a thesis received from Wolters Kluwer.

13.2. Baseline characteristics (139)

Patient demographics and baseline characteristics were generally well balanced between the placebo and intervention group (**Table 3**). At baseline, 24-hour urinary protein and calcium excretion were available in 106 participants (53 within the eplerenone group and 53 within the placebo group, respectively). Of the 110 randomized study participants 10 (9.1%) had diabetes and 81 (73.6%) had arterial hypertension. All participating subjects were Caucasians.

Mean age was 66.7 ± 9.9 years, and 87 were females (79.1%). Median iPTH was 100.3 (82.3-123.9) pg/mL and mean albumin-corrected plasma calcium was 2.62 ± 0.14 mmol/L, while 24-h urinary calcium excretion was 6.6 ± 3.4 mmol/24h. Moreover, 24-h urinary albumin was 10.0 (7.0-19.0) mg/24h and 24-h urinary and protein excretion was 90.6 (72.3-107.9) mg/24h.

Mean office BP was $144 \pm 19/89 \pm 11$ mmHg, while mean 24-hours BP was $126.8 \pm 12.1/77.6 \pm 8.6$ mmHg. The prevalence of arterial hypertension was as high as 73.6%. Accordingly mean E/e' ratio, as a measure of LV filling pressures, was 11.1 ± 4.9 , and median LV mass index calculated according to the modified Devereux formula was 102.8 (82.0-123.4) g/m². The prevalence of LV hypertrophy was 52%.

Median levels of NT-proBNP were 113.5 (60.7-189.3) pg/mL, while mean LV ejection fraction was in the normal range with 62.5 ± 8.2 %.

Median levels of bone turnover markers among 97 patients who completed the trial were 3.84 (3.25–4.74) U/L for TRAP, 0.435 (0.243–0.770) ng/mL for CTX, 52.9 (34.7–75.6) ng/mL for P1NP, 22.5 (16.2–36.4) ng/mL for OC, and 19.9 (15.5–26.5) µg/L for BALP.

Table 3: Demographic and Clinical Baseline Characteristics (139)

Characteristics	Total (n=110)	Eplerenone (n=54)	Placebo (n=56)	P value
Age, years	66.7 ± 9.9	67.3 ± 8.9	66.2 ± 10.8	0.571
Gender, % female	79.1	79.6	78.6	0.892
Body mass index, kg/m ²	28.2 ± 4.7	28.0 ± 4.0	28.5 ± 5.3	0.550
iPTH ^{Roche} , pg/mL	100.3 (82.3-123.9)	96.4 (82.5-116.0)	103.7 (81.3-129.8)	0.605
iPTH ^{Diasorin} , pg/mL	86.4 (66.0-111.5)	85.0 (66.0-108.0)	89.5 (65.2-113.7)	0.755
Normocalcemic/hypercalcemic pHPT, %	28.2/71.8	35.2/64.8	21.4/78.6	0.110
Parathyroidectomy indicated, %	43.6	44.4	42.9	0.867
Corrected plasma calcium, mmol/L	2.62 ± 0.14	2.60 ± 0.12	2.65 ± 0.14	0.041
Plasma phosphorus, mmol/L	0.79 ± 0.12	0.79 ± 0.09	0.78 ± 0.14	0.557
Plasma potassium, mmol/L	4.08 ± 0.29	4.06 ± 0.33	4.10 ± 0.26	0.449
25-hydroxyvitamin D, ng/mL	34.9 ± 11.7	34.7 ± 10.9	35.1 ± 12.5	0.840
eGFR, ml/min/1.73m ²	79.0 ± 14.4	77.8 ± 14.0	80.2 ± 14.9	0.378
24-hour urinary albumin, mg/24h	10.0 (7.0-19.0)	11.0 (6.0-17.0)	9.0 (7.0-20.5)	0.992
24-hour urinary protein, mg/24h	90.6 (72.3-107.9)	86.3 (70.0-105.0)	95.0 (78.3-109.3)	0.101
24-hour urinary calcium, mmol/24h	6.6 ± 3.4	7.0 ± 3.4	6.2 ± 3.4	0.237
Hypertension, %	73.6	70.4	76.8	0.447
Office systolic BP, mm Hg	144 ± 19	147 ± 19	141 ± 19	0.105
Office diastolic BP, mm Hg	89 ± 11	92 ± 12	86 ± 10	0.015
24 hour systolic ambulatory BP, mm Hg	126.8 ± 12.1	126.4 ± 12.8	127.2 ± 11.5	0.747
24 hour diastolic ambulatory BP, mm Hg	76.7 ± 8.3	77.6 ± 8.6	75.8 ± 8.1	0.247
NT-proBNP, pg/mL	113.5 (60.7-189.3)	132.0 (66.0-215.7)	103.5 (53.2-180.2)	0.262
Active smokers, %	13.6	7.4	19.6	0.063
Diabetes mellitus, %	9.1	3.7	14.3	0.055
Dyslipidemia, %	63.6	68.5	58.9	0.298
Previous myocardial infarction, %	7.3	9.3	5.4	0.433
CRP, mg/L	1.5 (0.6-2.7)	1.2 (0.6-2.3)	1.6 (0.8-3.2)	0.102
LV ejection fraction, %	62.5 ± 8.2	62.6 ± 9.9	62.4 ± 6.2	0.881
E/e' (average)	11.1 ± 4.9	11.8 ± 6.0	10.3 ± 3.3	0.135
LV mass index, g/m ²	102.8 (82.0-123.4)	105.7 (79.3-125.9)	102.0 (86.0-120.6)	0.639
LV end-diastolic septum, mm	11.4 ± 2.0	11.7 ± 2.3	11.2 ± 1.6	0.261
LV end-diastolic posterior wall, mm	10.8 ± 2.0	11.1 ± 1.9	10.6 ± 1.9	0.158
LV end-diastolic diameter, mm	46.9 ± 7.3	46.6 ± 7.8	47.2 ± 6.7	0.662
LV end-systolic diameter, mm	29.7 ± 6.5	30.0 ± 7.5	29.5 ± 5.4	0.717
LV end-diastolic volume, mL	80.5 (68.2-95.0)	81.0 (67.0-95.0)	80.0 (70.0-96.0)	0.873
LV end-systolic volume, mL	30.0 (24.0-38.0)	29.0 (24.0-39.0)	30.0 (23.0-37.0)	0.942
Cinacalcet treatment, %	12.7	14.8	10.7	0.521
Calcium supplementation, %	7.3	7.4	7.1	0.958
Vitamin D supplementation, %	48.2	42.6	53.6	0.251
Antihypertensive therapy				
ACE-inhibitors, %	17.3	16.1	18.5	0.735
AT II blockers, %	24.5	22.2	26.8	0.580
Beta blocker, %	40.0	40.7	39.3	0.877
Loop diuretics, %	2.7	3.7	1.8	0.539
Thiazide diuretics, %	28.2	29.6	26.8	0.741
Calcium channel blocker, %	22.7	18.5	26.8	0.303
History of HRT, %	27.3	31.5	23.2	0.333
Bisphosphonate therapy, %	11.8	9.3	14.3	0.416

Data are presented as means with standard deviation, medians with interquartile range or as percentages. Group comparisons (eplerenone vs placebo) at baseline were done by unpaired student's t test, Mann-Whitney U test or Chi Square test where appropriate.

PTH parathyroid hormone; pHPT primary hyperparathyroidism; eGFR, estimated glomerular filtration rate according to the CKD-EPI formula; BP, blood pressure; NT-proBNP, N-terminal pro-B-type natriuretic peptide; CRP, C-reactive protein; E, early diastolic peak velocity of transmitral inflow; e', early diastolic peak velocity of mitral annulus; LV, LV; HRT, hormone replacement therapy

At baseline, the subjects in the eplerenone group had lower mean corrected plasma calcium values compared with those in the placebo group (2.60 ± 0.12 vs 2.65 ± 0.14 , $p=0.041$). The distribution of subjects with regard to iPTH_{Roche}, iPTH_{Diasorin}, age, sex, BMI, 25-hydroxyvitamin D and eGFR was similar in both groups (P-value for all between-group comparisons > 0.5). Subjects in the eplerenone group had lower mean office diastolic BP values at baseline as compared with the placebo group. The distribution of ongoing drug use at baseline was similar between the groups. (139)

13.3. Primary endpoint (139)

Median iPTH_{Roche} and iPTH_{Diasorin} concentrations of the 97 randomized participants, who completed the follow-up visit, were at baseline 96.4 (82.6-118.9) and 85.0 (65.8-109.0) pg/mL in the eplerenone group, respectively, and 108.4 (83.3-132.3) pg/mL and 92.3 (68.4-120.0) pg/mL in the placebo group, respectively. Compared with placebo, eplerenone treatment did not cause significant changes in iPTH_{Roche} and iPTH_{Diasorin} concentrations (baseline to week 8) with a mean treatment effect (95% CI) of 1.0 (0.9 to 1.1; $p=0.777$) and -0.3 (-11.8 to 11.1; $p=0.892$) pg/mL, respectively (**Table 4**). Additional adjustment for plasma albumin adjusted calcium concentration did not materially alter the results. (139)

Table 4: Primary outcome variables at baseline and follow-up, and changes from baseline in study participants with available values at both study visits (139)

Characteristics	Baseline	Follow-up	Mean change from baseline	Treatment effect	P value
iPTH^{Roche}					
Eplerenone (n=48)	110.9 ± 54.6	105.7 ± 43.9	-5.1 (-14.0 to 3.8)	1.0 (0.9 to 1.1)	0.777
Placebo (n=48)	117.1 ± 55.6	110.1 ± 40.4	-7.0 (-15.7 to 1.7)		
iPTH^{Diasorin}					
Eplerenone (n=48)	97.9 ± 58.3	91.0 ± 45.7	-6.9 (-17.3 to 3.5)	-0.3 (-11.8 to 11.1)	0.892
Placebo (n=49)	103.7 ± 62.7	94.9 ± 48.0	-8.8 (-19.4 to 5.3)		

iPTH, intact parathyroid hormone.

Patients with normocalcemic pHPT revealed a weak trend for decreased iPTH_{Roche} and iPTH_{Diasorin} concentrations in the eplerenone group compared with placebo ($p=0.140$ and $p=0.143$, respectively). We did not find a significant interaction in regard to corrected plasma calcium concentrations ($p=0.759$). When comparing the pre- versus post-intervention effect of each treatment arm, eplerenone therapy significantly reduced the levels of iPTH_{Roche} and iPTH_{Diasorin} over 8 weeks (iPTH_{Roche}: -8.3 [-13.9 to -2.8]; $p=0.006$; iPTH_{Diasorin}: -6.9 [-13.8 to -0.04]; $p=0.049$). (139)

13.4. Secondary endpoints (139, 143)

ABPM showed significant reductions in 24-hour systolic and diastolic BP values in the eplerenone group. Compared with placebo, the reduction in mean 24-hour systolic and diastolic ABP (in mm Hg) were -6.5 (-9.6 to -3.4 ; $P < 0.001$) mmHg and -3.9 (-5.8 to -1.9 ; $p < 0.001$) mmHg, respectively (**Table 5**). (139)

NT-proBNP levels decreased from 240.0 ± 422.8 to 162.5 ± 228.7 pg/mL in the eplerenone group and increased from 161.6 ± 201.2 to 168.1 ± 264.5 pg/mL in the placebo group, with a mean treatment effect of -28.4 (-121.5 to 64.6 ; $p=0.112$). (139)

Eplerenone had no effect on 24-h urinary albumin excretion (mean treatment effect -6.3 [-14.2 to 1.6] mg/24h, $p=0.237$), 24-h urinary protein excretion (-4.1 [-14.9 to 6.8] mg/24h, $p=0.428$) or 24-h urinary calcium excretion (-0.96 [-2.0 to 0.1] mmol/24h, $p=0.114$).

Similarly, there were no effects on LV ejection fraction (mean treatment effect -0.3 [-3.1 to 2.5], $p=0.967$), E/e' ratio (-0.9 [-2.2 to 0.5], $p=0.178$), LV mass index (4.4 [-5.7 to 14.5], $p=0.433$) and indices of LV structure. Further details are shown in **Table 5**.(139)

Table 5: Secondary outcome variables at baseline and follow-up, and changes from baseline in study participants with available values at both study visits (139)

Characteristics	Baseline	Follow-up	Mean change from baseline	Treatment effect	P value
24-hour SBP, mmHg					
Eplerenone (n=48)	126.8 ± 13.2	118.7 ± 9.9	-8.1 (-11.1 to -5.1)	-6.3 (-9.4 to -3.3)	<0.001
Placebo (n=46)	126.8 ± 11.4	125.0 ± 10.9	-1.8 (-3.9 to 0.4)		
24-hour DBP, mmHg					
Eplerenone (n=48)	77.3 ± 8.8	71.9 ± 7.0	-5.3 (-7.2 to -3.5)	-3.7 (-5.7 to -1.7)	<0.001
Placebo (n=46)	75.2 ± 8.2	74.3 ± 7.6	-0.9 (-2.4 to 0.5)		
24-hour UAE, mg/24h					
Eplerenone (n=35)	16.8 ± 22.2	11.4 ± 8.0	-7.0 (-17.4 to 3.3)	-6.3 (-14.2 to 1.6)	0.237
Placebo (n=34)	21.1 ± 36.8	18.7 ± 27.6	-2.6 (-9.2 to 3.9)		
24-hour UPE, mg/24h					
Eplerenone (n=48)	86.7 ± 31.3	82.1 ± 27.4	-4.6 (-13.1 to 3.9)	-4.1 (-14.9 to 6.8)	0.428
Placebo (n=47)	100.8 ± 52.1	93.7 ± 40.9	-7.1 (-17.7 to 3.5)		
24-hour UC, mmol/24h					
Eplerenone (n=48)	6.2 ± 3.6	5.5 ± 2.9	-0.7 (-1.5 to 0.1)	0.96 (-2.0 to 0.1)	0.114
Placebo (n=47)	6.9 ± 3.4	7.0 ± 4.1	0.1 (-0.8 to 0.9)		
Corrected PC, mmol/L					
Eplerenone (n=48)	2.60 ± 0.13	2.61 ± 0.13	0.0 (-0.0 to 0.0)	0.0 (-0.04 to 0.04)	0.918
Placebo (n=49)	2.64 ± 0.14	2.65 ± 0.16	0.0 (-0.0 to 0.0)		
NT-proBNP					
Eplerenone (n=48)	240.0±422.8	162.5±228.7	-77.4 (-201.6 to 46.8)	-28.4 (-121.5 to 64.6)	0.112
Placebo (n=49)	161.6±201.2	168.1±264.5	6.5 (-44.6 to 57.7)		
LV ejection fraction					
Eplerenone (n=48)	62.3 ± 10.4	61.2 ± 8.3	-1.1 (-3.5 to 1.2)	-0.3 (-3.1 to 2.5)	0.967
Placebo (n=48)	61.8 ± 6.1	61.3 ± 7.5	-0.6 (-3.0 to 1.9)		
E/E' ratio					
Eplerenone (n=48)	11.9 ± 6.3	10.7 ± 4.0	-1.1 (-2.7 to 0.5)	-0.9 (-2.2 to 0.5)	0.178
Placebo (n=45)	10.6 ± 3.2	11.0 ± 3.5	0.5 (-0.3 to 1.2)		
LV mass index					
Eplerenone (n=42)	107.6 ± 41.0	109.0 ± 38.9	1.4 (-6.2 to 8.9)	4.4 (-5.7 to 14.5)	0.433
Placebo (n=40)	106.1 ± 25.6	103.6 ± 24.2	-2.5 (-11.0 to 5.9)		
LV ED posterior wall					
Eplerenone (n=42)	10.9 ± 1.9	10.6 ± 2.0	-0.3 (-1.0 to 0.4)	0.1 (-0.8 to 0.7)	0.773
Placebo (n=40)	10.8 ± 1.9	10.6 ± 1.6	-0.2 (-0.9 to 0.4)		
LV ED diameter, mm					
Eplerenone (n=42)	46.4 ± 7.9	47.5 ± 7.5	1.1 (-0.7 to 3.0)	2.1 (-0.2 to 4.4)	0.088
Placebo (n=40)	47.4 ± 6.7	46.0 ± 5.9	-1.4 (-3.4 to 0.7)		
LV ES diameter, mm					
Eplerenone (n=42)	30.0 ± 7.6	30.4 ± 7.9	0.3 (-1.3 to 1.9)	1.0 (-1.2 to 3.2)	0.374
Placebo (n=40)	29.3 ± 5.4	28.9 ± 5.4	-0.5 (-2.2 to 1.3)		
LV ED volume, mL					
Eplerenone (n=46)	88.3 ± 40.5	91.1 ± 47.3	2.8 (-5.1 to 10.8)	4.2 (-6.8 to 15.1)	0.457
Placebo (n=47)	84.9 ± 25.1	84.0 ± 29.3	-0.9 (-8.8 to 7.0)		
LV ES volume, mL					
Eplerenone (n=47)	36.9 ± 31.1	36.4 ± 30.9	-0.5 (-5.4 to 4.5)	0.8 (-5.3 to 6.9)	0.799
Placebo (n=47)	33.4 ± 14.6	33.0 ± 12.5	-0.4 (-4.8 to 4.1)		

SBP/DBP, systolic/diastolic blood pressure; UAE, urinary albumin; UPE, protein excretion; UC, urinary calcium; PC, plasma calcium; LV, LV; E, early diastolic peak velocity of transmitral inflow; e', early diastolic peak velocity of mitral annulus. NT-proBNP, N-terminal pro-B-type natriuretic peptide; ED/ES enddiastolic/endsystolic.

When compared to placebo, eplerenone had no significant effect on TRAP (mean treatment effect 0.16 [-0.11 to 0.42] U/l, P = 0.088), CTX (0.00 [-0.1 to 0.1] ng/mL, P = 0.986), P1NP (4.87 [-3.17 to 12.92] ng/mL, P = 0.257), BALP (-1.21 [-3.19 to 0.78] µg/L, P = 0.278) or osteocalcin (-2.31 [-6.17 to 1.55] ng/mL, P = 0.342), as demonstrated in **Table 6**. (143)

Table 6: Outcome variables at baseline and follow-up, and changes from baseline in study participants with available values at both study visits (143)

	Baseline	Follow-up	Mean change from baseline	Treatment effect	P-value
TRAP					
Eplerenone (n=48)	4.00 +/- 0.95	3.92 +/- 1.10	0.07 (-0.11 to 0.26)	0.16 (-0.11 to 0.42)	0.088
Placebo (n=48)	4.16 +/- 1.371	4.21 +/- 1.26	-0.05 (-0.26 to 1.51)		
CTX					
Eplerenone (n=44)	0.54 +/- 0.41	0.52 +/- 0.34	0.02 (-0.07 to 0.11)	0.00 (-0.1 to 0.1)	0.986
Placebo (n=44)	0.61 +/- 0.54	0.56 +/- 0.43	0.05 (-0.04 to 0.15)		
P1NP					
Eplerenone (n=48)	57.05 +/- 33.27	55.31 +/- 30.18	1.74 (-4.48 to 7.95)	4.87 (-3.17 to 12.92)	0.257
Placebo (n=48)	59.69 +/- 48.28	61.86 +/- 35.32	-2.17 (-10.28 to 5.95)		
BALP					
Eplerenone (n=48)	19.63 +/-7.37	10.19 +/- 8.76	-0.56 (-2.14 to 1.01)	-1.21 (-3.19 to 0.78)	0.278
Placebo (n=48)	23.50 +/- 11.35	22.40 +/- 10.55	1.10 (-0.15 to 2.35)		
Osteocalcin					
Eplerenone (n=48)	27.11 +/- 15.54	26.82 +/- 15.00	0.29 (-3.02 to 3.59)	-2.31 (-6.17 to 1.55)	0.342
Placebo (n=48)	28.64 +/- 20.5	25.51 +/- 15.4	3.13 (-0.16 to 6.4)		

Data at baseline and follow-up are shown as medians with interquartile range; change from baseline data are shown as means (with 95% confidence interval)

Abbreviations: TRAP, tartrate-resistant acid phosphatase; CTX, carboxy-terminal collagen crosslinks; P1NP, N-terminal propeptide of procollagen type 1; BALP, bone-specific alkaline phosphatase

13.5. **Safety endpoints and adverse events (139)**

Plasma potassium increased significantly by 0.19 (0.10–0.27) mmol/l to an average of 4.23 (\pm 0.33) mmol/l ($P < 0.001$) in the eplerenone group but not in the placebo group during 8 weeks of treatment ($P = 0.019$). Interestingly, before dose titration of eplerenone at week 4, no significant increase of plasma potassium levels compared with placebo was observed ($P = 0.475$). Downtitration of the study drug occurred in two patients (1.8%) in the placebo group because of eGFR less than 50 ml/min per 1.73m² and in eight patients (7.3%) in the treatment group because of mild hyperkalemia [plasma potassium > 5.0 and < 5.5 mmol/l (plasma potassium: 5.3 mmol/l); $n = 1$]; eGFR less than 50 ml/min per 1.73m² ($n = 6$); and patient's will ($n = 1$). No trial patient developed severe hyperkalemia (plasma potassium > 5.5 mmol/l) or eGFR less than 30 ml/min per 1.73m². Signs or symptoms that could be causally related to eplerenone were reported in 35 (31.8%) patients, 14 (25%) in the placebo group and 21 (38.9%) in the eplerenone group ($P = 0.120$). No patient experienced gynecomastia or other antiandrogenic side-effects. The incidence of adverse events or serious adverse events was comparable between the groups. Serious adverse events occurred in three patients (1.2%): one in the placebo group (one fracture) and two in the treatment group (one fracture, one acute diverticulitis). Discontinuation because of serious adverse events was observed in one patient in the treatment group (i.e., myotonic dystrophy and subsequent fall resulting in wrist fracture), but not in the placebo group. Adverse events occurred in 48 (43.6%) patients, 23 (41.1%) in the placebo group, and 25 (46.3%) in the eplerenone group ($P = 0.582$). The most frequent events were nausea (3.7% eplerenone, 5.4% placebo), symptomatic BP reduction (11.1% eplerenone, 3.6% placebo) and eGFR less than or equal to 50ml/min per 1.73m² (14.8% eplerenone, 7.1% placebo). At the final visit only one patient within the treatment group had a mild hyperkalemia (plasma potassium: 5.3mmol/l). No fatal events occurred during the trial. (139)

13.6. **Cross-sectional analyses (143)**

There were no significant differences between treatment groups with regards to any of the bone markers. In Pearson correlation analyses, TRAP was associated

with plasma PAC (Pearson $r=-0.205$, $P=0.044$) but not with PRC (Pearson $r=-0.025$, $P=0.805$) or the ARR (Pearson $r=-0.040$, $P=0.694$). After multivariate adjustment the relationship between TRAP and PAC was non-significant (adjusted beta-coefficient = -0.100 , $P = 0.346$). There were no further significant correlations between PAC, PRC or the ARR with any of the bone markers. Details are shown in **Table 7**. (143)

Table 7: Cross-sectional bi-variate correlations between bone turnover markers and parameters of the renin-angiotensin-aldosterone system (143)

Characteristics	PAC		PRC		ARR	
	r	P-value	r	P-value	r	P-value
TRAP, U/L	-0.205	0.044*	-0.025	0.805	-	0.694
β -Crosslaps, ng/mL	-0.059	0.576	0.100	0.342	-	0.248
P1NP, ng/mL	-0.092	0.373	-0.018	0.863	-	0.910
BALP, μ g/L	-0.036	0.730	0.143	0.163	-	0.123
Osteocalcin, ng/mL	-0.082	0.424	0.087	0.395	-	0.258
						0.116

All variables were log-transformed before use in parametrical procedures. Pearson correlation was used to assess relationships between variables. r represents Pearson correlation coefficient.

Abbreviations: PAC, plasma aldosterone concentration; PRC, plasma renin concentration; ARR, aldosterone-to-renin ratio; TRAP, tartrate-resistant acid phosphatase; CTX, carboxy-terminal collagen crosslinks; P1NP, N-terminal propeptide of procollagen type 1; BALP, bone-specific alkaline phosphatase. * significant in bivariate correlation analysis which turned non-significant in multivariate linear regression analysis.

14. Discussion

In this work, we report on the results of the first trial that tested MR antagonism in patients with pHPT. We included females and males with pHPT across the whole disease spectrum ranging from normo- to hypercalcemic pHPT. Eplerenone as compared with placebo did not significantly modify iPTH concentrations after 8 weeks of treatment. However, eplerenone significantly reduced 24-hour systolic and diastolic ABP. Effects on parameters of cardiac function and structure were neutral, although LV systolic and diastolic function parameters trended towards improvement. There were no significant effects on markers of bone turnover. Plasma potassium increased dose-dependently in the treatment group, while no cases of severe hyperkalemia were documented. Overall, eplerenone was well tolerated and adverse events were well balanced between the treatment arms.

Mounting evidence points towards a clinically relevant mutual relationship between aldosterone and PTH.(146–148) By binding to PTH/PTH-related peptide receptors and voltage-gated L-type calcium channels, PTH directly and indirectly triggers production of aldosterone from adrenal ZG cells.(149) Concordantly, PTH infusion induced increased urinary tetrahydroaldosterone and BP in healthy adults.(18) In line, pHPT patients had decreased concentrations of plasma aldosterone and renin activity after parathyroidectomy.(135) It is therefore tempting to hypothesize that aldosterone synthesis may be stimulated in pHPT, and that aldosterone, vice versa, may further augment PTH synthesis by activating the MR on parathyroid cells.

Aspects of study design

The potentially stimulatory effect of aldosterone induced MR-activation on PTH synthesis in pHPT is unknown. The synthesis of the MR in normal parathyroid cells and in parathyroid adenoma suggests direct modulatory capacities of aldosterone on PTH secretion. However, in our study effects of eplerenone on iPTH concentrations in pHPT patients were neutral. The reason for the lack of apparent benefit from MR antagonism on PTH levels may result from the fact that the treatment group had higher calcium levels and thus a more severe phenotype

of pHPT. This may reflect a higher degree of autonomy and, consequently, less sensitivity of parathyroid cells to MR antagonism. Nevertheless, vitamin D application lowers PTH in pHPT patients suggesting that PTH-regulatory mechanisms are active in pHPT but potentially via different pathways.(150)

It must be noted that existing effects of eplerenone may have been missed due to an inadequate trial design. One crucial aspect that needs to be discussed is the definition of pHPT that we applied. PHPT is defined by inadequate levels of PTH in relation to circulating calcium levels. There is no doubt that hyperparathyroidism in concomitance with hypercalcemia (or with normocalcemia in cinacalcet-treated patients) is the classical constellation of pHPT and can be easily diagnosed. In developed countries, however, a considerable percentage of pHPT patients is diagnosed at early disease stages, when they may be 1) normocalcemic; or 2) present with hypercalcemia and normal but inadequately high PTH. In the patient group with high normal calcium and increased PTH levels, potential causes of secondary form of hyperparathyroidism need to be excluded. Well established conditions that may cause hyperparathyroidism include vitamin D deficiency and chronic kidney disease. Concomitant use of thiazide diuretics has been brought up by several leaders in the field to cause hyperparathyroidism, but this remains heavily debated. The suggested PTH raising effect of thiazides is not based on solid evidence and has even been contradicted in clinical trials.(142, 151) Given that, we *a priori* excluded patients either with a eGFR below than or equal to 50 ml/min/1.73m² or with 25(OH)D levels below 20 ng/ml from trial participation. However, patients with thiazide use were defined as eligible for trial participation.

In fact, almost 30% of participants were treated with thiazides and it may be argued that hyperparathyroidism in these patients may rather be a consequence of thiazide intake and not of autonomous hyperfunction of parathyroid glands. However, the majority of patients with pHPT is treated for arterial hypertension for which thiazide treatment is recommended as first line therapy. Therefore, feasibility of the EPATH trial would have been massively hampered, if patients with thiazide treatment had been excluded from trial participation. Moreover, MR antagonism may as well reduce PTH levels in secondary hyperparathyroidism and

we consider it therefore unlikely that our results are neutral due to the high percentage of patients taking thiazide diuretics.

Another inadequate feature could be seen in the relatively long time interval of up to several hours between intake of the study drug and measurement of PTH levels at the respective study visits, because an existing treatment could be missed. In fact, the calcimimetic drug cinacalcet acutely lowers PTH levels in patients with hyperparathyroidism. However, the short-term effect of cinacalcet is not only due to the short half-life of cinacalcet of only 2-6 hours, but also to the fact that effects are mediated via the CaSR which acutely regulates PTH secretion.⁽⁵⁾ On contrary, considering the half-life of eplerenone of 4-6 hours and the genomic pathway of aldosterone-MR induced PTH synthesis, iPTH measurement within five hours after taking the study drug should have provided a sufficient time window in our view to detect effects of eplerenone on iPTH concentrations. This is supported by the significant BP reduction and the observed increase in potassium levels induced by eplerenone in our study. In fact, blood pressure reduction and increase of potassium are two major (side) effects of MR antagonism and are commonly used as surrogates of sufficient study medication intake in MR antagonism trials. Moreover, iPTH concentrations within the placebo group were virtually unaltered which underlines that our primary outcome measure was well standardized.

Moreover, the negative trial results could be explained by incompliance of study participants resulting in insufficient achievement of plasma levels of eplerenone. Although we did not measure eplerenone levels in blood or serum at the end of the active trial period, the evident effects on blood pressure and potassium contradicts the perception of low patient compliance. Moreover, the high estimated compliance based on pill counting suggests a high adherence of our study participants to the prescribed drug regimen.

Another noteworthy aspect of our work is the fact that intention-to-treat analyses revealed neutral effects of eplerenone on bone turnover markers in pHPT. As summarized in the introduction, accumulating evidence suggests a tight interweavement between aldosterone, bone turnover and PTH secretion in pHPT. This leads to the perception that blockade of the MR may impact on bone health in pHPT, either directly via effects on bone cells or indirectly by lowering PTH. (89,

148) Previous observational studies support the notion that these mechanistic links may translate into bone protective properties of MR antagonism. In fact, human individuals with primary aldosteronism are at increased risk to have osteoporosis when compared to subjects with essential hypertension.(152) More so, blockade of the MR or adrenalectomy showed statistical association with better bone health in primary aldosteronism cohorts.(153, 154) Nevertheless, in the present study an effect of eplerenone on bone turnover markers was lacking. Thereby, our work which is the first RCT in this topic contrasts these previous studies only showing neutral effects of MR blockade on bone health, at least in pHPT.

Urinary calcium excretion

Hyperparathyroidism is highly prevalent among patients with primary aldosteronism and reduction of PTH levels in concomitance with increase of ionized calcium have been consistently described.(20, 155, 156) It was suggested that this commonly observed secondary hyperparathyroidism in the setting of hyperaldosteronism may be due to renal calcium loss. By contrast, the present investigation did not confirm potential MR-aldosterone mediated calciuretic effects in patients with pHPT as only a non-significant trend for decreased 24-hour urinary calcium excretion in the eplerenone group was observed. However, as the EPATH was not powered to detect effects of eplerenone on urinary calcium excretion, this non-significant result may simply represent a type II error.

Arterial hypertension

The prevalence of arterial hypertension in the EPATH trial cohort was as high as 73.6% which is consistent with prior studies.(110) In fact, arterial hypertension is a common comorbidity in patients with pHPT, also in those with mild disease.(111) Even patients with the normocalcemic phenotype of pHPT appear to be at increased risk of arterial hypertension.(112, 113) In an analysis of the overall EPATH study cohort that was published after publication of the main EPATH trial results, plasma PTH was not correlated with mean nocturnal systolic BP (Pearson $r=0.074$, $P=0.39$) or mean nocturnal diastolic BP ($r=0.060$, $p=0.48$). (157) Only in the subset of 76 patients without PTH-modifying medication (inhibitors of the renin-

angiotensin-aldosterone system, cinacalcet, diuretics) there was a significant association between PTH and mean nocturnal systolic BP even in multivariate regression analyses (adjusted β -coefficient=0.284, $P=0.040$). The correlation between PTH and mean nocturnal blood pressure, pulse wave velocity and left ventricular mass index is illustrated in **Figure 8**.(158)

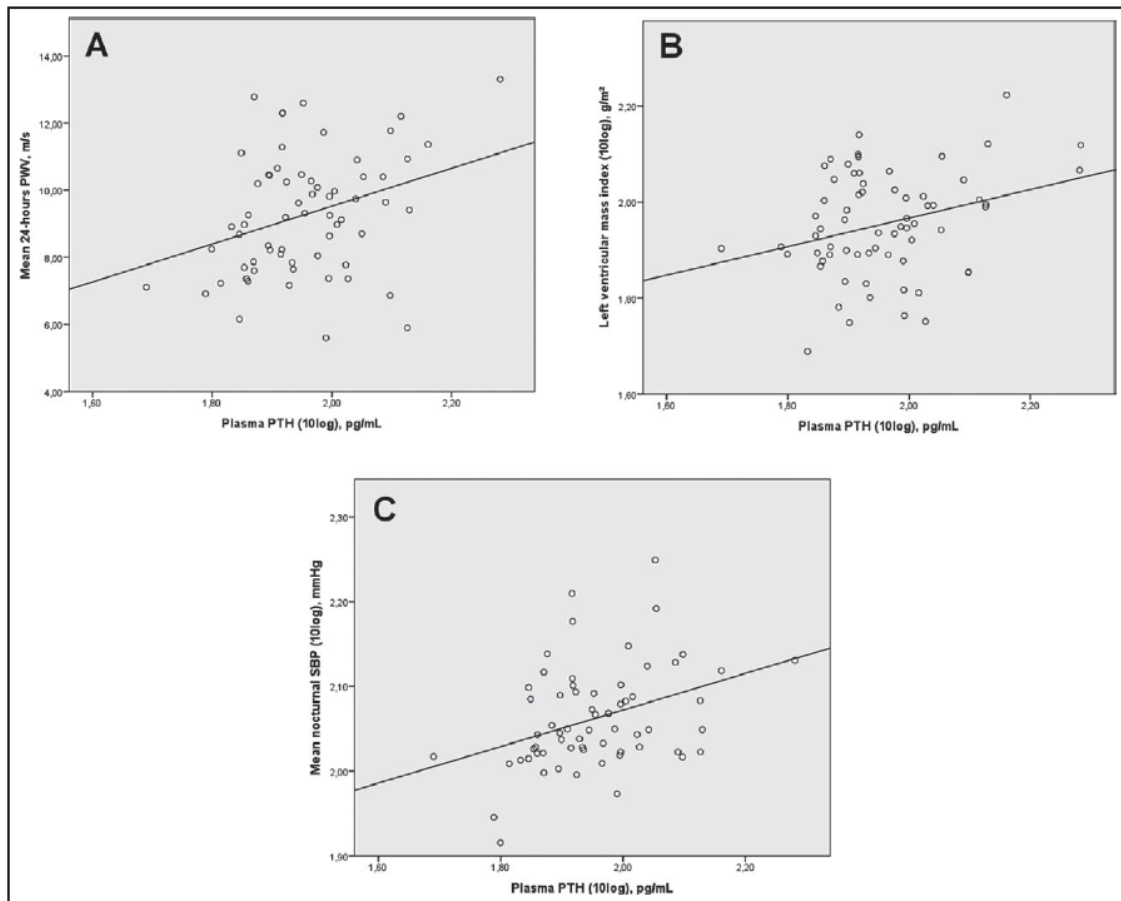

Figure 8: Scatter plots depicting bivariate correlations between plasma parathyroid hormone and mean 24-hour pulse wave velocity (A), mean left ventricular mass index (B), and mean nocturnal systolic blood pressure (C).

Abbreviations: PTH, parathyroid hormone; PWV, pulse wave velocity; LVMI, left ventricular mass index; SBP, systolic blood pressure

Cited from Wetzel J, Pilz S, Gröbler MR, Fahrleitner-Pammer A, Dimai HP, et al. Plasma parathyroid hormone and cardiovascular disease in treatment-naive patients with primary hyperparathyroidism: The EPATH trial. *J Clin Hypertens* (Greenwich). 2017 Nov;19(11):1173-1180.(158)

<https://onlinelibrary.wiley.com/doi/full/10.1111/jch.13064> Permission for reuse in a thesis received from John Wiley and Sons.

Other studies of pHPT populations could not report direct relationships between PTH levels and systolic BP.(159, 160) By contrast, observational studies in patients without pHPT consistently reported direct associations between PTH and BP.(116, 117) As a limiting factor, previous analyses in pHPT populations were small and comprised patients with a heterogeneous pattern of concomitant drug

regimens. Of note, PTH infusions increased BP in healthy volunteers, suggesting that arterial hypertension is caused by PTH excess per se, either via direct or indirect effects.(18) It was previously hypothesized that the interaction between calcium regulatory hormones homeostasis and aldosterone may increase the likelihood of arterial hypertension. (161) In patients with pHPT, a concomitant decline of both BP and aldosterone concentrations was reported after parathyroidectomy (131, 161), although other studies found conflicting results regarding effects of parathyroidectomy on BP.(162–164) More so, Rydberg et al. even found increased postoperative 24-hour ambulatory systolic BP levels after parathyroidectomy in hypertensive patients with pHPT.(119) Nevertheless, one recent meta-analysis pooled data from 457 patients with pHPT including 15 studies or trials to analyze effects of parathyroidectomy on LV mass. The authors found a significant reduction of LV mass and concluded that PTH may cause LV hypertrophy in pHPT.(129) In fact, the present trial demonstrates a significant reduction of BP by eplerenone which effectively reduced 24-h systolic and diastolic BP, with an effect size comparable to BP reductions observed in patients with essential arterial hypertension.(165) Our data lay ground to establishing MR antagonism with eplerenone as a safe and effective antihypertensive treatment option in this particular patient group.

Cardiac structure and function parameters

We had hypothesized that potential effects of eplerenone on cardiac structure and function could be mediated by the effect of eplerenone on PTH. However, while the effect on PTH was absolutely neutral, there was a trend towards improving diastolic function as measured by E/e' and reducing NT-proBNP which is a surrogate of cardiac (mainly left-sided) volume overload. In fact, several trials have pointed towards beneficial effects of MR antagonism on diastolic dysfunction. In the ALDO-DHF trial 422 patients with early heart failure with preserved ejection fraction (previously entitled as “diastolic heart failure”) were treated with spironolactone or placebo for 1 year. While there was no effect on functional capacity as measured by peak VO_2 during cardiopulmonary exercise testing, spironolactone significantly reduced E/e' .(166) While the TOPCAT trial failed to show significant effects of spironolactone on cardiovascular outcome parameters

in patients with heart failure with preserved ejection fraction (167), the currently ongoing SPIRIT-HF trial will finally answer this question.

Gender disparity

Strikingly, there was a large gender disparity in our study with 79% being females. However, this matches well with data from the literature suggesting that females are approximately three-fold diagnosed with pHPT than males.(28) Some authors speculated this may be due to screening bias because pHPT is often diagnosed during osteoporosis screening which is routinely performed in women when they reach a postmenopausal state.(28) In fact, screening for the EPATH study was mainly performed in the Outpatient Clinic of the Division of Endocrinology and Diabetology of the Medical University of Graz which has a well-known clinical focus on osteoporosis diagnostics and treatment. This may explain, why the proportion of females in our study was even slightly higher than in other pHPT cohorts.

Normocalcemic primary hyperparathyroidism

Approximately 30% of participants in our cohort showed biochemical features of normocalcemic pHPT. This is comparable to recently published data from a Belgian tertiary care center cohort where the prevalence of normocalcemic pHPT among 131 patients with pHPT was 19%.(59) Normocalcemic pHPT is considered, by most authors, to represent an early form of pHPT as these patients present with lower PTH levels and lower adenoma weight, as surrogate parameters of disease severity, than those with hypercalcemic disease.(168) Strikingly, in a longitudinal study it was found that only approximately 20% of pHPT patients with the normocalcemic variant evolve into the hypercalcemic variant within the following three years.(141) Nevertheless, they exhibit about the same prevalence of target organ damage with regards to osteoporosis and nephrolithiasis as patients with hypercalcemic pHPT (59) so that there is common agreement that pHPT patients should be screened for target organ damage regardless of their calcium levels. In our study, there was a tendency, although far from significance, of PTH-lowering effects of eplerenone among patients with normocalcemic pHPT. Although these non-significant results should be interpreted with caution, this may indicate that patients with normocalcemic pHPT could benefit from MR antagonism in terms of

disease control. On the other hand, another explanation could be found in pathophysiological differences between normocalcemic and hypercalcemic pHPT patients. In fact, it was speculated that the pathophysiology underlying normocalcemia in pHPT patients could be explained by relative PTH resistance of target tissues, as these patients were described to have lower urinary calcium levels.(169) However, in another study, this finding could not be reproduced.(141) Of note, adenomatous parathyroid gland tissue is only identifiable in a certain proportion of normocalcemic pHPT patients, while parathyroid gland hyperplasia can often be discovered as the underlying pathology. Therefore, it should be discussed, in our view, whether a non-classical stimulus for secondary pHPT could be present in what is commonly described as normocalcemic pHPT.

Besides impaired kidney function, vitamin D deficiency, use of diuretics and use of bisphosphonates, several other factors may increase PTH levels. As extensively summarized in this thesis, MR activation in PTH secreting cells of the parathyroid gland may promote PTH secretion. Therefore, it may be speculated that relative aldosterone excess, commonly encountered in patients with heart failure, could be another condition predisposing patients to develop secondary hyperparathyroidism. Although the null finding of our trial argues against the PTH-stimulatory role of MR activation, it may still be the case that parathyroid glands in patients with pHPT are uncoupled from extrinsic stimuli such as aldosterone. Following that argumentation, MR antagonism may be effective in reducing PTH levels in patients with heart failure with secondary hyperparathyroidism, despite our negative trial. To explore the role of relative aldosterone excess among the group of normocalcemic trial participants is however beyond the scope of this thesis. The fact that there was a tendency of PTH reduction by eplerenone in this subgroup of normocalcemic patients may serve as a rationale to further explore the role of relative aldosterone excess in normocalcemic pHPT.

Another condition that may modify PTH secretion is changes in pH. Acidosis can increase circulation levels of ionized calcium so that a potential effect of acidosis itself on PTH levels is difficult to assess. In several studies on dogs, however, Lopez et al induced both acute metabolic acidosis and acute respiratory acidosis while maintaining calcium levels in the normal range. They found that PTH secretion was negatively correlated with pH in a way that acidosis significantly

increased PTH levels. This effect was observed even when hypocalcemia induced by acidosis was prevented, see also **Figure 9**.(170) These experimental data are in line with clinical data from Movilli et al showing that correction of metabolic acidosis in hemodialysis patients was associated with a decrease in PTH levels.
(171)

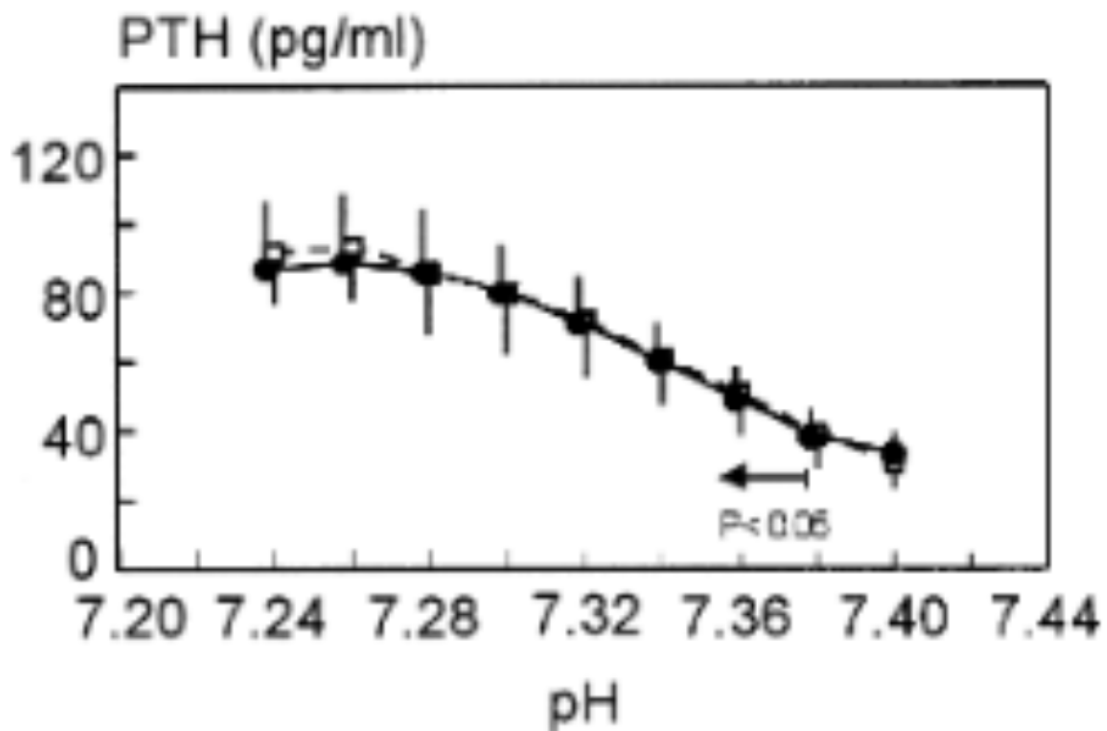

Figure 9: Effect of blood pH on parathyroid hormone in dogs with metabolic acidosis (closed circles) and with respiratory acidosis (open square).

Abbreviations: PTH, parathyroid hormone

Cited from Lopez I, Aguilera-Tejero E, Felsenfeld AJ, Estepa JC, Rodriguez M. Direct effect of acute metabolic and respiratory acidosis on parathyroid hormone secretion in the dog. J Bone Miner Res. 2002 Sep;17(9):1691-700.(170)

<https://www.ncbi.nlm.nih.gov/pubmed/12211440> Permission for reuse in a thesis received from John Wiley and Sons.

A general drawback of all studies on the normocalcemic pHPT variant is clearly the low number of studied subjects and the single-center design of most studies. Both these limitations make it very difficult to generalize study results. Moreover, the potential role of acidosis or relative aldosterone excess in normocalcemic pHPT remains under-investigated. To this date, there is no clear consensus regarding the pathophysiological background underlying normocalcemic pHPT nor exist specific guidelines or recommendations for its diagnosis and treatment.

Limitations and strengths

The major strength of our study is the fact that this is the first RCT testing eplerenone in patients with pHPT. High attention was placed upon the good clinical and biochemical characterization of pHPT patients and comprehensive assessment of biomarkers of cardiovascular health. Following international recommendations, we performed genetic screening for FHH (142). Moreover, the diagnosis of pHPT was confirmed for every participant in standardized procedures.

The limitations of our study include its single-center design using a selected cohort of Caucasian and overwhelmingly female patients with pHPT, which may not be generalizable to other study populations. Another drawback is the relatively short treatment period with eplerenone. We cannot exclude that longer treatment may have changed PTH levels although our data do not point towards this. Moreover, it remains unclear, whether MR antagonism may reveal PTH lowering effects in other populations, ie. in patients with chronic heart failure and secondary hyperparathyroidism. By having applied a relatively broad definition of pHPT we cannot exclude that in isolated cases individuals with secondary hyperparathyroidism may have entered the trial.

Conclusion

Conclusively, eplerenone failed to alter PTH levels, surrogate markers of cardiovascular health or bone turnover markers in patients with pHPT. Nevertheless, eplerenone significantly reduced BP levels in pHPT patients. These data provide first evidence from a randomized and placebo-controlled trial that MR antagonism may not directly affect PTH levels, at least in pHPT, but is a safe tool to improve BP control.

Given the strong rationale behind the hypothesized interaction between PTH and the RAAS, further trials are warranted to test potential effects of MR blockade on PTH and consecutive biomarkers in populations other than pHPT.

15. Bibliography

1. Khan AA, Hanley DA, Rizzoli R, Bollerslev J, Young JEM, Rejnmark L et al. Primary hyperparathyroidism: review and recommendations on evaluation, diagnosis, and management. A Canadian and international consensus. *Osteoporos Int* 2017; 28(1):1–19.
2. Murray TM, Rao LG, Divieti P, Bringhurst FR. Parathyroid hormone secretion and action: evidence for discrete receptors for the carboxyl-terminal region and related biological actions of carboxyl-terminal ligands. *Endocr Rev* 2005; 26(1):78–113.
3. Marx UC, Adermann K, Bayer P, Forssmann WG, Rösch P. Solution structures of human parathyroid hormone fragments hPTH(1-34) and hPTH(1-39) and bovine parathyroid hormone fragment bPTH(1-37). *Biochem Biophys Res Commun* 2000; 267(1):213–20.
4. Tfelt-Hansen J, Brown EM. The calcium-sensing receptor in normal physiology and pathophysiology: a review. *Crit Rev Clin Lab Sci* 2005; 42(1):35–70.
5. Verheyen N, Pilz S, Eller K, Kienreich K, Fahrleitner-Pammer A, Pieske B et al. Cinacalcet hydrochloride for the treatment of hyperparathyroidism. *Expert Opin Pharmacother* 2013; 14(6):793–806.
6. Alvarez-Hernández D, Naves M, Santamaría I, Menárguez J, Torregrosa V, Cannata J. Response of parathyroid glands to calcitriol in culture: Is this response mediated by the genetic polymorphisms in vitamin D receptor? *Kidney Int Suppl* 2003; (85):S19-22.
7. Fraser WD. Hyperparathyroidism. *Lancet* 2009; 374(9684):145–58.
8. Calvi LM, Sims NA, Hunzelman JL, Knight MC, Giovannetti A, Saxton JM et al. Activated parathyroid hormone/parathyroid hormone-related protein receptor in osteoblastic cells differentially affects cortical and trabecular bone. *J Clin Invest* 2001; 107(3):277–86.
9. Krege JH, Lane NE, Harris JM, Miller PD. PINP as a biological response marker during teriparatide treatment for osteoporosis. *Osteoporos Int* 2014; 25(9):2159–71.

10. Ben-awadh AN, Delgado-Calle J, Tu X, Kuhlenschmidt K, Allen MR, Plotkin LI et al. Parathyroid hormone receptor signaling induces bone resorption in the adult skeleton by directly regulating the RANKL gene in osteocytes. *Endocrinology* 2014; 155(8):2797–809.
11. Silva BC, Bilezikian JP. Parathyroid hormone: anabolic and catabolic actions on the skeleton. *Curr Opin Pharmacol* 2015; 22:41–50.
12. Rutkovskiy A, Stensløyken K-O, Vaage IJ. Osteoblast Differentiation at a Glance. *Med Sci Monit Basic Res* 2016; 22:95–106.
13. Pilz S, Tomaschitz A, März W, Cavalier E, Ritz E. Aldosterone and parathyroid hormone: a complex and clinically relevant relationship. *Calcif Tissue Int* 2010; 87(4):373–4.
14. Maniero C, Fassina A, Guzzardo V, Lenzini L, Amadori G, Pelizzo MR et al. Primary hyperparathyroidism with concurrent primary aldosteronism. *Hypertension* 2011; 58(3):341–6.
15. Brown JM, Williams JS, Luther JM, Garg R, Garza AE, Pojoga LH et al. Human interventions to characterize novel relationships between the renin-angiotensin-aldosterone system and parathyroid hormone. *Hypertension* 2014; 63(2):273–80.
16. Olgaard K, Lewin E, Bro S, Daugaard H, Egfjord M, Pless V. Enhancement of the stimulatory effect of calcium on aldosterone secretion by parathyroid hormone. *Miner Electrolyte Metab* 1994; 20(5):309–14.
17. Fardella C, Rodriguez-Portales JA. Intracellular calcium and blood pressure: comparison between primary hyperparathyroidism and essential hypertension. *J Endocrinol Invest* 1995; 18(11):827–32.
18. Hulter HN, Melby JC, Peterson JC, Cooke CR. Chronic continuous PTH infusion results in hypertension in normal subjects. *J Clin Hypertens* 1986; 2(4):360–70.
19. Isales CM, Barrett PQ, Brines M, Bollag W, Rasmussen H. Parathyroid hormone modulates angiotensin II-induced aldosterone secretion from the adrenal glomerulosa cell. *Endocrinology* 1991; 129(1):489–95.

20. Resnick LM, Laragh JH. Calcium metabolism and parathyroid function in primary aldosteronism. *Am J Med* 1985; 78(3):385–90.
21. Grant FD, Mandel SJ, Brown EM, Williams GH, Seely EW. Interrelationships between the renin-angiotensin-aldosterone and calcium homeostatic systems. *J Clin Endocrinol Metab* 1992; 75(4):988–92.
22. Jespersen B, Randløv A, Abrahamsen J, Fogh-Andersen N, Kanstrup IL. Effects of PTH(1-34) on blood pressure, renal function, and hormones in essential hypertension: the altered pattern of reactivity may counteract raised blood pressure. *Am J Hypertens* 1997; 10(12 Pt 1):1356–67.
23. Pilz S, Tomaschitz A, Drechsler C, Ritz E, Boehm BO, Grammer TB et al. Parathyroid hormone level is associated with mortality and cardiovascular events in patients undergoing coronary angiography. *Eur Heart J* 2010; 31(13):1591–8.
24. Beard CM, Heath H, O'Fallon WM, Anderson JA, Earle JD, Melton LJ. Therapeutic radiation and hyperparathyroidism. A case-control study in Rochester, Minn. *Arch Intern Med* 1989; 149(8):1887–90.
25. Fujiwara S, Sposto R, Ezaki H, Akiba S, Neriishi K, Kodama K et al. Hyperparathyroidism among atomic bomb survivors in Hiroshima. *Radiat Res* 1992; 130(3):372–8.
26. Schneider AB, Gierlowski TC, Shore-Freedman E, Stovall M, Ron E, Lubin J. Dose-response relationships for radiation-induced hyperparathyroidism. *J Clin Endocrinol Metab* 1995; 80(1):254–7.
27. Rasmuson T, Tavelin B. Risk of parathyroid adenomas in patients with thyrotoxicosis exposed to radioactive iodine. *Acta Oncol* 2006; 45(8):1059–61.
28. Miller BS, Dimick J, Wainess R, Burney RE. Age- and sex-related incidence of surgically treated primary hyperparathyroidism. *World J Surg* 2008; 32(5):795–9.
29. Laat JM de, van Leeuwen RS, Valk GD. The Importance of an Early and Accurate MEN1 Diagnosis. *Front Endocrinol (Lausanne)* 2018; 9:533.
30. Udelsman R, Åkerström G, Biagini C, Duh Q-Y, Miccoli P, Niederle B et al. The surgical management of asymptomatic primary hyperparathyroidism: proceedings of the Fourth International Workshop. *J Clin Endocrinol Metab* 2014; 99(10):3595–606.

31. Fuleihan GE-H. Familial benign hypocalciuric hypercalcemia. *J Bone Miner Res* 2002; 17 Suppl 2:N51-6.
32. Shinall MC, Dahir KM, Broome JT. Differentiating familial hypocalciuric hypercalcemia from primary hyperparathyroidism. *Endocr Pract* 2013; 19(4):697–702.
33. Christensen SE, Nissen PH, Vestergaard P, Heickendorff L, Brixen K, Mosekilde L. Discriminative power of three indices of renal calcium excretion for the distinction between familial hypocalciuric hypercalcaemia and primary hyperparathyroidism: a follow-up study on methods. *Clin Endocrinol (Oxf)* 2008; 69(5):713–20.
34. Nissen PH, Christensen SE, Heickendorff L, Brixen K, Mosekilde L. Molecular genetic analysis of the calcium sensing receptor gene in patients clinically suspected to have familial hypocalciuric hypercalcemia: phenotypic variation and mutation spectrum in a Danish population. *J Clin Endocrinol Metab* 2007; 92(11):4373–9.
35. Guarnieri V, Canaff L, Yun FHJ, Scillitani A, Battista C, Muscarella LA et al. Calcium-sensing receptor (CASR) mutations in hypercalcemic states: studies from a single endocrine clinic over three years. *J Clin Endocrinol Metab* 2010; 95(4):1819–29.
36. Nesbit MA, Hannan FM, Howles SA, Babinsky VN, Head RA, Cranston T et al. Mutations affecting G-protein subunit $\alpha 11$ in hypercalcemia and hypocalcemia. *N Engl J Med* 2013; 368(26):2476–86.
37. Nesbit MA, Hannan FM, Howles SA, Reed AAC, Cranston T, Thakker CE et al. Mutations in *AP2S1* cause familial hypocalciuric hypercalcemia type 3. *Nat Genet* 2013; 45(1):93–7.
38. Vaidya A, Curhan GC, Paik JM, Kronenberg H, Taylor EN. Hypertension, Antihypertensive Medications, and Risk of Incident Primary Hyperparathyroidism. *J Clin Endocrinol Metab* 2015; 100(6):2396–404.
39. Vaidya A, Curhan GC, Paik JM, Wang M, Taylor EN. Physical Activity and the Risk of Primary Hyperparathyroidism. *J Clin Endocrinol Metab* 2016; 101(4):1590–7.

40. Vaidya A, Curhan GC, Paik JM, Wang M, Taylor EN. Body Size and the Risk of Primary Hyperparathyroidism in Women: A Cohort Study. *J Bone Miner Res* 2017; 32(9):1900–6.
41. Stenström G, Heedman PA. Clinical findings in patients with hypercalcaemia. A final investigation based on biochemical screening. *Acta Med Scand* 1974; 195(6):473–7.
42. Mundy GR, Cove DH, Fisker R. Primary hyperparathyroidism: changes in the pattern of clinical presentation. *Lancet* 1980; 1(8182):1317–20.
43. Wermers RA, Khosla S, Atkinson EJ, Hodgson SF, O'Fallon WM, Melton LJ. The rise and fall of primary hyperparathyroidism: a population-based study in Rochester, Minnesota, 1965-1992. *Ann Intern Med* 1997; 126(6):433–40.
44. Griebeler ML, Kearns AE, Ryu E, Hathcock MA, Melton LJ, Wermers RA. Secular trends in the incidence of primary hyperparathyroidism over five decades (1965-2010). *Bone* 2015; 73:1–7.
45. Adami S, Marcocci C, Gatti D. Epidemiology of primary hyperparathyroidism in Europe. *J Bone Miner Res* 2002; 17 Suppl 2:N18-23.
46. Castellano E, Attanasio R, Boriano A, Borretta G. The clinical presentation of primary hyperparathyroidism of primary hyperparathyroidism: a southern European perspective over the last two decades. *Endocr Pract* 2018.
47. Mazzaglia PJ, Berber E, Kovach A, Milas M, Esselstyn C, Siperstein AE. The changing presentation of hyperparathyroidism over 3 decades. *Arch Surg* 2008; 143(3):260–6.
48. Cusano NE, Maalouf NM, Wang PY, Zhang C, Cremers SC, Haney EM et al. Normocalcemic hyperparathyroidism and hypoparathyroidism in two community-based nonreferral populations. *J Clin Endocrinol Metab* 2013; 98(7):2734–41.
49. Siilin H, Lundgren E, Mallmin H, Mellström D, Ohlsson C, Karlsson M et al. Prevalence of primary hyperparathyroidism and impact on bone mineral density in elderly men: MrOs Sweden. *World J Surg* 2011; 35(6):1266–72.
50. Sharma S, Rastogi A, Bhadada SK, Singh P, Varshney S, Behera A et al. Prevalence and predictors of primary hyperparathyroidism among patients with urolithiasis. *Endocr Pract* 2017; 23(11):1311–5.

51. Parks J. Hyperparathyroidism in Nephrolithiasis. *Arch Intern Med* 1980; 140(11):1479.
52. Kim J-K, Chai YJ, Chung JK, Hwang K-T, Heo SC, Kim S-J et al. The prevalence of primary hyperparathyroidism in Korea: a population-based analysis from patient medical records. *Ann Surg Treat Res* 2018; 94(5):235–9.
53. Bergström I, Landgren B-M, Freyschuss B. Primary hyperparathyroidism is common in postmenopausal women with forearm fracture and low bone mineral density. *Acta Obstet Gynecol Scand* 2007; 86(1):61–4.
54. Plum LA, DeLuca HF. Vitamin D, disease and therapeutic opportunities. *Nat Rev Drug Discov* 2010; 9(12):941–55.
55. Arya AK, Bhadada SK, Mukherjee S, Singh P, Rana SS, Dahiya D et al. Frequency & predictors of pancreatitis in symptomatic primary hyperparathyroidism. *Indian J Med Res* 2018; 148(6):721–7.
56. Kumar A, Kumar PG, Pujahari AK, Sampath S. Hypercalcemia Related Pancreatitis. *Medical Journal Armed Forces India* 2010; 66(4):385–6.
57. Silverberg SJ, Clarke BL, Peacock M, Bandeira F, Boutroy S, Cusano NE et al. Current issues in the presentation of asymptomatic primary hyperparathyroidism: proceedings of the Fourth International Workshop. *J Clin Endocrinol Metab* 2014; 99(10):3580–94.
58. Vestergaard P. Primary hyperparathyroidism and nephrolithiasis. *Ann Endocrinol (Paris)* 2015; 76(2):116–9.
59. Pierreux J, Bravenboer B. Normocalcemic Primary Hyperparathyroidism: A Comparison with the Hypercalcemic Form in a Tertiary Referral Population. *Horm Metab Res* 2018; 50(11):797–802.
60. Rejnmark L, Vestergaard P, Mosekilde L. Nephrolithiasis and renal calcifications in primary hyperparathyroidism. *J Clin Endocrinol Metab* 2011; 96(8):2377–85.
61. Joborn C, Hetta J, Niklasson F, Rastad J, Wide L, Agren H et al. Cerebrospinal fluid calcium, parathyroid hormone, and monoamine and purine metabolites and the blood-brain barrier function in primary hyperparathyroidism. *Psychoneuroendocrinology* 1991; 16(4):311–22.

62. Prager G, Kalaschek A, Kaczirek K, Passler C, Scheuba C, Sonneck G et al. Parathyroidectomy improves concentration and retentiveness in patients with primary hyperparathyroidism. *Surgery* 2002; 132(6):930-5; discussion 935-6.
63. Khan A, Bilezikian J, Bone H, Gurevich A, Lakatos P, Misiorowski W et al. Cinacalcet normalizes serum calcium in a double-blind randomized, placebo-controlled study in patients with primary hyperparathyroidism with contraindications to surgery. *Eur J Endocrinol* 2015; 172(5):527–35.
64. Peacock M, Bolognese MA, Borofsky M, Scumpia S, Sterling LR, Cheng S et al. Cinacalcet treatment of primary hyperparathyroidism: biochemical and bone densitometric outcomes in a five-year study. *J Clin Endocrinol Metab* 2009; 94(12):4860–7.
65. Rolighed L, Rejnmark L, Sikjaer T, Heickendorff L, Vestergaard P, Mosekilde L et al. Vitamin D treatment in primary hyperparathyroidism: a randomized placebo controlled trial. *J Clin Endocrinol Metab* 2014; 99(3):1072–80.
66. Lewiecki EM, Miller PD. Skeletal effects of primary hyperparathyroidism: bone mineral density and fracture risk. *J Clin Densitom* 2013; 16(1):28–32.
67. Kersch-Schindl K, Riss P, Krestan C, Rauner M, Bieglmayer C, Gleiss A et al. Bone metabolism in patients with primary hyperparathyroidism before and after surgery. *Horm Metab Res* 2012; 44(6):476–81.
68. Thorsen K, Kristoffersson AO, Lorentzon RP. Changes in bone mass and serum markers of bone metabolism after parathyroidectomy. *Surgery* 1997; 122(5):882–7.
69. Koumakis E, Souberbielle J-C, Sarfati E, Meunier M, Maury E, Gallimard E et al. Bone mineral density evolution after successful parathyroidectomy in patients with normocalcemic primary hyperparathyroidism. *J Clin Endocrinol Metab* 2013; 98(8):3213–20.
70. Costa AG, Bilezikian JP. Bone turnover markers in primary hyperparathyroidism. *J Clin Densitom* 2013; 16(1):22–7.
71. Bollerslev J, Rosen T, Mollerup CL, Nordenström J, Baranowski M, Franco C et al. Effect of surgery on cardiovascular risk factors in mild primary hyperparathyroidism. *J Clin Endocrinol Metab* 2009; 94(7):2255–61.

72. Ejlsmark-Svensson H, Bislev LS, Lajlev S, Harsløf T, Rolighed L, Sikjaer T et al. Prevalence and Risk of Vertebral Fractures in Primary Hyperparathyroidism: A Nested Case-Control Study. *J Bone Miner Res* 2018; 33(9):1657–64.
73. Sitges-Serra A, Girvent M, Pereira JA, Jimeno J, Nogués X, Cano FJ et al. Bone mineral density in menopausal women with primary hyperparathyroidism before and after parathyroidectomy. *World J Surg* 2004; 28(11):1148–52.
74. Rao DS, Phillips ER, Divine GW, Talpos GB. Randomized controlled clinical trial of surgery versus no surgery in patients with mild asymptomatic primary hyperparathyroidism. *J Clin Endocrinol Metab* 2004; 89(11):5415–22.
75. Rubin MR, Bilezikian JP, McMahon DJ, Jacobs T, Shane E, Siris E et al. The natural history of primary hyperparathyroidism with or without parathyroid surgery after 15 years. *J Clin Endocrinol Metab* 2008; 93(9):3462–70.
76. Vestergaard P, Mollerup CL, Frøkjær VG, Christiansen P, Blichert-Toft M, Mosekilde L. Cohort study of risk of fracture before and after surgery for primary hyperparathyroidism. *BMJ* 2000; 321(7261):598–602.
77. Bandeira F, Griz LH, Bandeira C, Pinho J, Lucena CS, Alencar C et al. Prevalence of cortical osteoporosis in mild and severe primary hyperparathyroidism and its relationship with bone markers and vitamin D status. *J Clin Densitom* 2009; 12(2):195–9.
78. Schlüter KD, Piper HM. Cardiovascular actions of parathyroid hormone and parathyroid hormone-related peptide. *Cardiovasc Res* 1998; 37(1):34–41.
79. Baczynski R, Massry SG, Kohan R, Magott M, Saglikes Y, Brautbar N. Effect of parathyroid hormone on myocardial energy metabolism in the rat. *Kidney Int* 1985; 27(5):718–25.
80. Smith CS, Bottomley PA, Schulman SP, Gerstenblith G, Weiss RG. Altered creatine kinase adenosine triphosphate kinetics in failing hypertrophied human myocardium. *Circulation* 2006; 114(11):1151–8.
81. Vidal A, Sun Y, Bhattacharya SK, Ahokas RA, Gerling IC, Weber KT. Calcium paradox of aldosteronism and the role of the parathyroid glands. *Am J Physiol Heart Circ Physiol* 2006; 290(1):H286-94.

82. Schlüter KD, Piper HM. Trophic effects of catecholamines and parathyroid hormone on adult ventricular cardiomyocytes. *Am J Physiol* 1992; 263(6 Pt 2):H1739-46.
83. Borkowski BJ, Cheema Y, Shahbaz AU, Bhattacharya SK, Weber KT. Cation dyshomeostasis and cardiomyocyte necrosis: the Fleckenstein hypothesis revisited. *Eur Heart J* 2011; 32(15):1846–53.
84. Kaye DM, Lefkovits J, Jennings GL, Bergin P, Broughton A, Esler MD. Adverse consequences of high sympathetic nervous activity in the failing human heart. *J Am Coll Cardiol* 1995; 26(5):1257–63.
85. Esler M, Jennings G, Korner P, Willett I, Dudley F, Hasking G et al. Assessment of human sympathetic nervous system activity from measurements of norepinephrine turnover. *Hypertension* 1988; 11(1):3–20.
86. Potthoff SA, Janus A, Hoch H, Frahnert M, Tossios P, Reber D et al. PTH-receptors regulate norepinephrine release in human heart and kidney. *Regul Pept* 2011; 171(1-3):35–42.
87. Cha H, Jeong HJ, Jang SP, Kim JY, Yang DK, Oh JG et al. Parathyroid hormone accelerates decompensation following left ventricular hypertrophy. *Exp Mol Med* 2010; 42(1):61–8.
88. Tastan I, Schreckenber R, Mufti S, Abdallah Y, Piper HM, Schlüter K-D. Parathyroid hormone improves contractile performance of adult rat ventricular cardiomyocytes at low concentrations in a non-acute way. *Cardiovasc Res* 2009; 82(1):77–83.
89. Tomaschitz A, Ritz E, Pieske B, Fahrleitner-Pammer A, Kienreich K, Horina JH et al. Aldosterone and parathyroid hormone: a precarious couple for cardiovascular disease. *Cardiovasc Res* 2012; 94(1):10–9.
90. Kamycheva E, Sundsfjord J, Jorde R. Serum parathyroid hormone level is associated with body mass index. The 5th Tromsø study. *Eur J Endocrinol* 2004; 151(2):167–72.
91. Hagström E, Ingelsson E, Sundström J, Hellman P, Larsson TE, Berglund L et al. Plasma parathyroid hormone and risk of congestive heart failure in the community. *Eur J Heart Fail* 2010; 12(11):1186–92.

92. Sugimoto T, Tanigawa T, Onishi K, Fujimoto N, Matsuda A, Nakamori S et al. Serum intact parathyroid hormone levels predict hospitalisation for heart failure. *Heart* 2009; 95(5):395–8.
93. Sambrook PN, Chen JS, March LM, Cameron ID, Cumming RG, Lord SR et al. Serum parathyroid hormone is associated with increased mortality independent of 25-hydroxy vitamin d status, bone mass, and renal function in the frail and very old: a cohort study. *J Clin Endocrinol Metab* 2004; 89(11):5477–81.
94. Sugimoto T, Dohi K, Onishi K, Watanabe K, Sato Y, Sugiura E et al. Interrelationship between haemodynamic state and serum intact parathyroid hormone levels in patients with chronic heart failure. *Heart* 2013; 99(2):111–5.
95. Loncar G, Bozic B, Dimkovic S, Prodanovic N, Radojicic Z, Cvorovic V et al. Association of increased parathyroid hormone with neuroendocrine activation and endothelial dysfunction in elderly men with heart failure. *J Endocrinol Invest* 2011; 34(3):e78-85.
96. Drüeke T, Fauchet M, Fleury J, Lesourd P, Toure Y, Le Pailleur C et al. Effect of parathyroidectomy on left-ventricular function in haemodialysis patients. *Lancet* 1980; 1(8160):112–4.
97. Goto N, Tominaga Y, Matsuoka S, Sato T, Katayama A, Habu T et al. Cardiovascular complications caused by advanced secondary hyperparathyroidism in chronic dialysis patients; special focus on dilated cardiomyopathy. *Clin Exp Nephrol* 2005; 9(2):138–41.
98. Altay H, Zorlu A, Bilgi M, Erol T, Yilmaz MB. Usefulness of parathyroid hormone as a predictor of heart failure with preserved ejection fraction. *Biomarkers* 2012; 17(5):447–54.
99. Øgard CG, Engholm G, Almdal TP, Vestergaard H. Increased mortality in patients hospitalized with primary hyperparathyroidism during the period 1977-1993 in Denmark. *World J Surg* 2004; 28(1):108–11.
100. Osto E, Fallo F, Pelizzo MR, Maddalozzo A, Sorgato N, Corbetti F et al. Coronary microvascular dysfunction induced by primary hyperparathyroidism is restored after parathyroidectomy. *Circulation* 2012; 126(9):1031–9.

101. Palmér M, Adami HO, Bergström R, Akerström G, Ljunghall S. Mortality after surgery for primary hyperparathyroidism: a follow-up of 441 patients operated on from 1956 to 1979. *Surgery* 1987; 102(1):1–7.
102. Ronni-Sivula H. Causes of death in patients previously operated on for primary hyperparathyroidism. *Ann Chir Gynaecol* 1985; 74(1):13–8.
103. Hedbäck G, Tisell LE, Bengtsson BA, Hedman I, Oden A. Premature death in patients operated on for primary hyperparathyroidism. *World J Surg* 1990; 14(6):829-35; discussion 836.
104. Ljunghall S, Jakobsson S, Joborn C, Palmér M, Rastad J, Akerström G. Longitudinal studies of mild primary hyperparathyroidism. *J Bone Miner Res* 1991; 6 Suppl 2:S111-6; discussion S121-4.
105. Hedbäck G, Odén A, Tisell LE. The influence of surgery on the risk of death in patients with primary hyperparathyroidism. *World J Surg* 1991; 15(3):399-405; discussion 406-7.
106. Nilsson I-L, Yin L, Lundgren E, Rastad J, Ekblom A. Clinical presentation of primary hyperparathyroidism in Europe--nationwide cohort analysis on mortality from nonmalignant causes. *J Bone Miner Res* 2002; 17 Suppl 2:N68-74.
107. Wermers RA, Khosla S, Atkinson EJ, Grant CS, Hodgson SF, O'Fallon WM et al. Survival after the diagnosis of hyperparathyroidism: a population-based study. *Am J Med* 1998; 104(2):115–22.
108. Yu N, Donnan PT, Leese GP. A record linkage study of outcomes in patients with mild primary hyperparathyroidism: the Parathyroid Epidemiology and Audit Research Study (PEARS). *Clin Endocrinol (Oxf)* 2011; 75(2):169–76.
109. Hedbäck GM, Odén AS. Cardiovascular disease, hypertension and renal function in primary hyperparathyroidism. *J Intern Med* 2002; 251(6):476–83.
110. Rosenthal FD, Roy S. Hypertension and hyperparathyroidism. *Br Med J* 1972; 4(5837):396–7.
111. Ring M, Farahnak P, Gustavsson T, Nilsson I-L, Eriksson MJ, Caidahl K. Arterial structure and function in mild primary hyperparathyroidism is not directly related to parathyroid hormone, calcium, or vitamin D. *PLoS ONE* 2012; 7(7):e39519.

112. Chen G, Xue Y, Zhang Q, Xue T, Yao J, Huang H et al. Is Normocalcemic Primary Hyperparathyroidism Harmful or Harmless? *J Clin Endocrinol Metab* 2015; 100(6):2420–4.
113. Lee P, Greenfield JR. 'Hyperaldosteronaemic or normocalcaemic' hyperparathyroidism? *Clin Endocrinol (Oxf)* 2015; 83(5):748–9.
114. Jorde R, Sneve M, Figenschau Y, Svartberg J, Waterloo K. Effects of vitamin D supplementation on symptoms of depression in overweight and obese subjects: randomized double blind trial. *J Intern Med* 2008; 264(6):599–609.
115. Kanbay M, Isik B, Akcay A, Ozkara A, Karakurt F, Turgut F et al. Relation between serum calcium, phosphate, parathyroid hormone and 'nondipper' circadian blood pressure variability profile in patients with normal renal function. *Am J Nephrol* 2007; 27(5):516–21.
116. Morfis L, Smerdely P, Howes LG. Relationship between serum parathyroid hormone levels in the elderly and 24 h ambulatory blood pressures. *J Hypertens* 1997; 15(11):1271–6.
117. Verheyen ND, Kienreich K, Gaksch M, van Ballegooijen AJ, Grüber MR, Hartaigh BÓ et al. Plasma Parathyroid Hormone Is Independently Related to Nocturnal Blood Pressure in Hypertensive Patients: The Styrian Hypertension Study. *J Clin Hypertens (Greenwich)* 2016; 18(6):543–50.
118. Norenstedt S, Pernow Y, Brismar K, Sääf M, Ekip A, Granath F et al. Primary hyperparathyroidism and metabolic risk factors, impact of parathyroidectomy and vitamin D supplementation, and results of a randomized double-blind study. *Eur J Endocrinol* 2013; 169(6):795–804.
119. Rydberg E, Birgander M, Bondeson A-G, Bondeson L, Willenheimer R. Effect of successful parathyroidectomy on 24-hour ambulatory blood pressure in patients with primary hyperparathyroidism. *Int J Cardiol* 2010; 142(1):15–21.
120. Walker MD, Fleischer JB, Di Tullio MR, Homma S, Rundek T, Stein EM et al. Cardiac structure and diastolic function in mild primary hyperparathyroidism. *J Clin Endocrinol Metab* 2010; 95(5):2172–9.

121. Farahnak P, Ring M, Caidahl K, Farnebo L-O, Eriksson MJ, Nilsson I-L. Cardiac function in mild primary hyperparathyroidism and the outcome after parathyroidectomy. *Eur J Endocrinol* 2010; 163(3):461–7.
122. Nilsson IL, Aberg J, Rastad J, Lind L. Left ventricular systolic and diastolic function and exercise testing in primary hyperparathyroidism-effects of parathyroidectomy. *Surgery* 2000; 128(6):895–902.
123. Piovesan A, Molineri N, Casasso F, Emmolo I, Ugliengo G, Cesario F et al. Left ventricular hypertrophy in primary hyperparathyroidism. Effects of successful parathyroidectomy. *Clin Endocrinol (Oxf)* 1999; 50(3):321–8.
124. Dalberg K, Brodin LA, Juhlin-Dannfelt A, Farnebo LO. Cardiac function in primary hyperparathyroidism before and after operation. An echocardiographic study. *Eur J Surg* 1996; 162(3):171–6.
125. Nuzzo V, Tauchmanovà L, Fonderico F, Trotta R, Fittipaldi MR, Fontana D et al. Increased intima-media thickness of the carotid artery wall, normal blood pressure profile and normal left ventricular mass in subjects with primary hyperparathyroidism. *Eur J Endocrinol* 2002; 147(4):453–9.
126. Stefenelli T, Mayr H, Bergler-Klein J, Globits S, Woloszczuk W, Niederle B. Primary hyperparathyroidism: incidence of cardiac abnormalities and partial reversibility after successful parathyroidectomy. *Am J Med* 1993; 95(2):197–202.
127. Kalla A, Krishnamoorthy P, Gopalakrishnan A, Garg J, Patel NC, Figueredo VM. Primary hyperparathyroidism predicts hypertension: Results from the National Inpatient Sample. *Int J Cardiol* 2017; 227:335–7.
128. Best CAE, Krishnan R, Malvankar-Mehta MS, MacNeil SD. Echocardiogram changes following parathyroidectomy for primary hyperparathyroidism: A systematic review and meta-analysis. *Medicine (Baltimore)* 2017; 96(43):e7255.
129. McMahon DJ, Carrelli A, Palmeri N, Zhang C, DiTullio M, Silverberg SJ et al. Effect of Parathyroidectomy Upon Left Ventricular Mass in Primary Hyperparathyroidism: A Meta-Analysis. *J Clin Endocrinol Metab* 2015; 100(12):4399–407.

130. Barkan A, Marilus R, Winkelsberg G, Yeshurun D, Blum I. Primary hyperparathyroidism: possible cause of primary hyperaldosteronism in a 60-year-old woman. *J Clin Endocrinol Metab* 1980; 51(1):144–7.
131. Pacifici R, Perry HM, Shieber W, Biglieri E, Droke DM, Avioli LV. Adrenal responses to subtotal parathyroidectomy for primary hyperparathyroidism. *Calcif Tissue Int* 1987; 41(3):119–23.
132. Jespersen B, Brock A, Charles P, Danielsen H, Sørensen SS, Pedersen EB. Unchanged noradrenaline reactivity and blood pressure after corrective surgery in primary hyperparathyroidism. *Scand J Clin Lab Invest* 1993; 53(5):479–86.
133. Gennari C, Nami R, Gonnelli S. Hypertension and primary hyperparathyroidism: the role of adrenergic and renin-angiotensin-aldosterone systems. *Miner Electrolyte Metab* 1995; 21(1-3):77–81.
134. Zia AA, Kamalov G, Newman KP, McGee JE, Bhattacharya SK, Ahokas RA et al. From aldosteronism to oxidative stress: the role of excessive intracellular calcium accumulation. *Hypertens Res* 2010; 33(11):1091–101.
135. Kovács L, Góth MI, Szabolcs I, Dohán O, Ferencz A, Szilágyi G. The effect of surgical treatment on secondary hyperaldosteronism and relative hyperinsulinemia in primary hyperparathyroidism. *Eur J Endocrinol* 1998; 138(5):543–7.
136. Fallo F, Rocco S, Pagotto U, Zangari M, Luisetto G, Mantero F. Aldosterone and pressor responses to angiotensin II in primary hyperparathyroidism. *J Hypertens Suppl* 1989; 7(6):S192-3.
137. Brunaud L, Germain A, Zarnegar R, Rancier M, Alrasheedi S, Caillard C et al. Serum aldosterone is correlated positively to parathyroid hormone (PTH) levels in patients with primary hyperparathyroidism. *Surgery* 2009; 146(6):1035–41.
138. Tomaschitz A, Fahrleitner-Pammer A, Pieske B, Verheyen N, Amrein K, Ritz E et al. Effect of eplerenone on parathyroid hormone levels in patients with primary hyperparathyroidism: a randomized, double-blind, placebo-controlled trial. *BMC Endocr Disord* 2012; 12:19.
139. Tomaschitz A, Verheyen N, Meinitzer A, Pieske B, Belyavskiy E, Brussee H et al. Effect of eplerenone on parathyroid hormone levels in patients with primary

hyperparathyroidism: results from the EPATH randomized, placebo-controlled trial. *J Hypertens* 2016; 34(7):1347–56.

140. Souberbielle JC, Cormier C, Kindermans C, Gao P, Cantor T, Forette F et al. Vitamin D status and redefining serum parathyroid hormone reference range in the elderly. *J Clin Endocrinol Metab* 2001; 86(7):3086–90.

141. Lowe H, McMahon DJ, Rubin MR, Bilezikian JP, Silverberg SJ. Normocalcemic primary hyperparathyroidism: further characterization of a new clinical phenotype. *J Clin Endocrinol Metab* 2007; 92(8):3001–5.

142. Eastell R, Brandi ML, Costa AG, D'Amour P, Shoback DM, Thakker RV. Diagnosis of asymptomatic primary hyperparathyroidism: proceedings of the Fourth International Workshop. *J Clin Endocrinol Metab* 2014; 99(10):3570–9.

143. Verheyen N, Grübler MR, Meinitzer A, Trummer C, Schwetz V, Amrein K et al. Effect of eplerenone on markers of bone turnover in patients with primary hyperparathyroidism - The randomized, placebo-controlled EPATH trial. *Bone* 2017; 105:212–7.

144. Nagueh SF, Smiseth OA, Appleton CP, Byrd BF, Dokainish H, Edvardsen T et al. Recommendations for the Evaluation of Left Ventricular Diastolic Function by Echocardiography: An Update from the American Society of Echocardiography and the European Association of Cardiovascular Imaging. *Eur Heart J Cardiovasc Imaging* 2016; 17(12):1321–60.

145. Lang RM, Badano LP, Mor-Avi V, Afilalo J, Armstrong A, Ernande L et al. Recommendations for cardiac chamber quantification by echocardiography in adults: an update from the American Society of Echocardiography and the European Association of Cardiovascular Imaging. *Eur Heart J Cardiovasc Imaging* 2015; 16(3):233–70.

146. Tomaschitz A, Pilz S. Interplay between sodium and calcium regulatory hormones: a clinically relevant research field. *Hypertension* 2014; 63(2):212–4.

147. Vaidya A, Brown JM, Williams JS. The renin-angiotensin-aldosterone system and calcium-regulatory hormones. *J Hum Hypertens* 2015; 29(9):515–21.

148. Tomaschitz A, Ritz E, Pieske B, Rus-Machan J, Kienreich K, Verheyen N et al. Aldosterone and parathyroid hormone interactions as mediators of metabolic and cardiovascular disease. *Metab Clin Exp* 2014; 63(1):20–31.
149. Rossier MF, Burnay MM, Vallotton MB, Capponi AM. Distinct functions of T- and L-type calcium channels during activation of bovine adrenal glomerulosa cells. *Endocrinology* 1996; 137(11):4817–26.
150. Shah VN, Shah CS, Bhadada SK, Rao DS. Effect of 25 (OH) D replacements in patients with primary hyperparathyroidism (PHPT) and coexistent vitamin D deficiency on serum 25(OH) D, calcium and PTH levels: a meta-analysis and review of literature. *Clin Endocrinol (Oxf)* 2014; 80(6):797–803.
151. Yacobi-Bach M, Serebro M, Greenman Y, Tordjman K, Stern N. Letter to the editor: Thiazides are not inducers of PTH secretion: a comment on normocalcemic hyperparathyroidism. *J Clin Endocrinol Metab* 2015; 100(2):L27-8.
152. Petramala L, Zinamosca L, Settevendemmie A, Marinelli C, Nardi M, Concistrè A et al. Bone and mineral metabolism in patients with primary aldosteronism. *Int J Endocrinol* 2014; 2014:836529.
153. Ceccoli L, Ronconi V, Giovannini L, Marcheggiani M, Turchi F, Boscaro M et al. Bone health and aldosterone excess. *Osteoporos Int* 2013; 24(11):2801–7.
154. Loh HH, Kamaruddin NA, Zakaria R, Sukor N. Improvement of bone turnover markers and bone mineral density following treatment of primary aldosteronism. *Minerva Endocrinol* 2018; 43(2):117–25.
155. Pilz S, Kienreich K, Drechsler C, Ritz E, Fahrleitner-Pammer A, Gaksch M et al. Hyperparathyroidism in patients with primary aldosteronism: cross-sectional and interventional data from the GECOH study. *J Clin Endocrinol Metab* 2012; 97(1):E75-9.
156. Maniero C, Fassina A, Seccia TM, Toniato A, Iacobone M, Plebani M et al. Mild hyperparathyroidism: a novel surgically correctable feature of primary aldosteronism. *J Hypertens* 2012; 30(2):390–5.
157. Verheyen N, Fahrleitner-Pammer A, Pieske B, Meinitzer A, Belyavskiy E, Wetzel J et al. Parathyroid hormone, aldosterone-to-renin ratio and fibroblast growth factor-23 as determinants of nocturnal blood pressure in primary

- hyperparathyroidism: the eplerenone in primary hyperparathyroidism trial. *J Hypertens* 2016; 34(9):1778–86.
158. Wetzel J, Pilz S, Grübler MR, Fahrleitner-Pammer A, Dimai HP, Lewinski Dv et al. Plasma parathyroid hormone and cardiovascular disease in treatment-naive patients with primary hyperparathyroidism: The EPATH trial. *J Clin Hypertens (Greenwich)* 2017; 19(11):1173–80.
159. Lumachi F, Camozzi V, Luisetto G, Zanella S, Basso SMM. Arterial blood pressure, serum calcium and PTH in elderly men with parathyroid tumors and primary hyperparathyroidism. *Anticancer Res* 2011; 31(11):3969–72.
160. Lumachi F, Ermani M, Luisetto G, Nardi A, Basso SMM, Camozzi V et al. Relationship between serum parathyroid hormone, serum calcium and arterial blood pressure in patients with primary hyperparathyroidism: results of a multivariate analysis. *Eur J Endocrinol* 2002; 146(5):643–7.
161. Resnick LM, Müller FB, Laragh JH. Calcium-regulating hormones in essential hypertension. Relation to plasma renin activity and sodium metabolism. *Ann Intern Med* 1986; 105(5):649–54.
162. Sancho JJ, Rouco J, Riera-Vidal R, Sitges-Serra A. Long-term effects of parathyroidectomy for primary hyperparathyroidism on arterial hypertension. *World J Surg* 1992; 16(4):732-5; discussion 736.
163. Heyliger A, Tangpricha V, Weber C, Sharma J. Parathyroidectomy decreases systolic and diastolic blood pressure in hypertensive patients with primary hyperparathyroidism. *Surgery* 2009; 146(6):1042–7.
164. Feldstein CA, Akopian M, Pietrobelli D, Olivieri A, Garrido D. Long-term effects of parathyroidectomy on hypertension prevalence and circadian blood pressure profile in primary hyperparathyroidism. *Clin Exp Hypertens* 2010; 32(3):154–8.
165. White WB, Carr AA, Krause S, Jordan R, Roniker B, Oigman W. Assessment of the novel selective aldosterone blocker eplerenone using ambulatory and clinical blood pressure in patients with systemic hypertension. *Am J Cardiol* 2003; 92(1):38–42.

166. Edelmann F, Wachter R, Schmidt AG, Kraigher-Krainer E, Colantonio C, Kamke W et al. Effect of spironolactone on diastolic function and exercise capacity in patients with heart failure with preserved ejection fraction: the Aldo-DHF randomized controlled trial. *JAMA* 2013; 309(8):781–91.
167. Pitt B, Pfeffer MA, Assmann SF, Boineau R, Anand IS, Claggett B et al. Spironolactone for heart failure with preserved ejection fraction. *N Engl J Med* 2014; 370(15):1383–92.
168. Kiriakopoulos A, Petralias A, Linos D. Classic Primary Hyperparathyroidism Versus Normocalcemic and Normohormonal Variants: Do They Really Differ? *World J Surg* 2018; 42(4):992–7.
169. Maruani G, Hertig A, Paillard M, Houillier P. Normocalcemic primary hyperparathyroidism: evidence for a generalized target-tissue resistance to parathyroid hormone. *J Clin Endocrinol Metab* 2003; 88(10):4641–8.
170. Lopez I, Aguilera-Tejero E, Felsenfeld AJ, Estepa JC, Rodriguez M. Direct effect of acute metabolic and respiratory acidosis on parathyroid hormone secretion in the dog. *J Bone Miner Res* 2002; 17(9):1691–700.
171. Movilli E, Zani R, Carli O, Sangalli L, Pola A, Camerini C et al. Direct effect of the correction of acidosis on plasma parathyroid hormone concentrations, calcium and phosphate in hemodialysis patients: a prospective study. *Nephron* 2001; 87(3):257–62.
172. Hecking M, Kainz A, Bielesz B, Plischke M, Beilhack G, Hörl WH, et al. Clinical evaluation of two novel biointact PTH(1-84) assays in hemodialysis patients. *Clin Biochem.* 2012 Dec;45(18):1645-51.